

The Performance Leader in Microwave Connectors

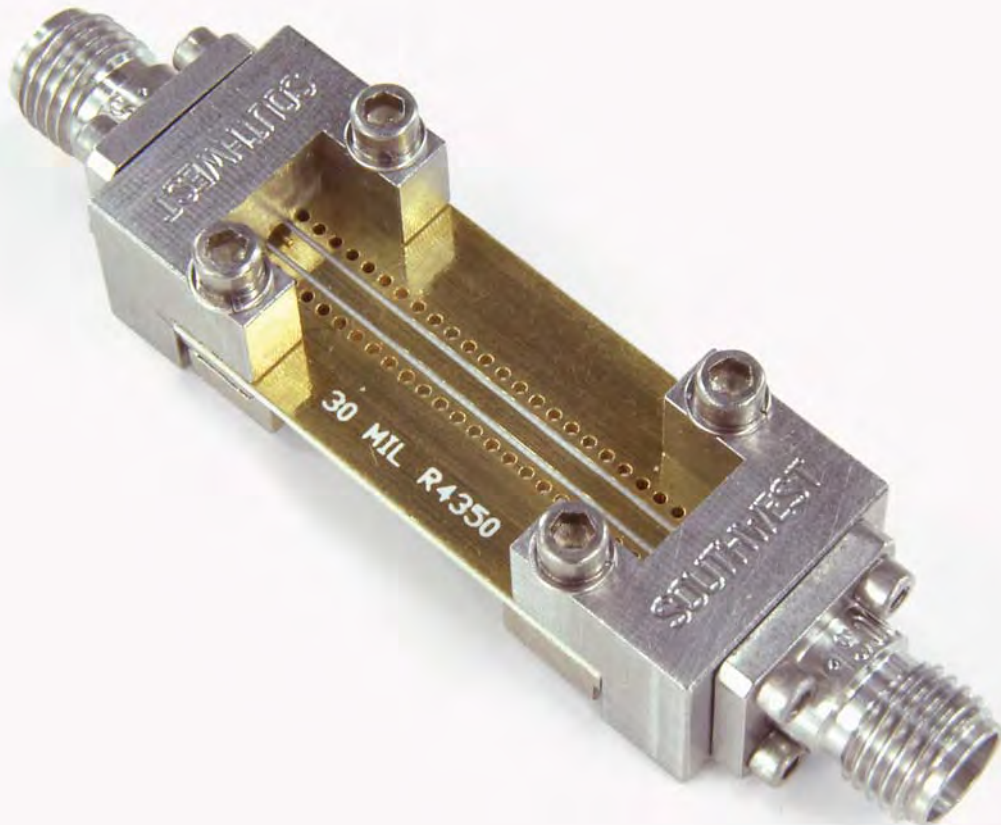

Optimizing Test Boards for 50 GHz End Launch Connectors
*Grounded Coplanar Launches and Through Lines on
30 mil Rogers 4350 with Comparison to Microstrip*



Southwest Microwave, Inc.

www.southwestmicrowave.com ■ *Tempe, Arizona USA*

Southwest Microwave, Inc.

Optimizing Test Boards for 50 GHz End Launch Connectors:

*Grounded Coplanar Launches and Through Lines on
30 mil Rogers 4350 with Comparison to Microstrip*

Copyright © 2007 by Southwest Microwave, Inc.

All rights reserved. Petra Microwave®, Ltd., Rogers Corporation®,

CST®-Computer Simulation Technology, and CST Microwave Studio® 2006 are all registered trademarks of their respective companies.

Table of Contents

Test Equipment and Techniques	2
Analyzer Workstation (HP 8510C)	2
Southwest Microwave Standard S-Parameter Plot	3
Electrical Performance	3
Purpose	4
Scope of the Evaluation	3
Comparison of GCPWG and Microstrip	3
Final Test Results	4
Southwest Microwave End Launch Connectors	5
Connector Model	5
End Launch Connector Features:	6
Review of the Original Test Board (2003)	6
S-Parameter Test Data / VSWR	7
Time Domain (TDR) Test Data	7
Reproduction of Original Test Board (2007)	8
3-D Simulation of the Original GCPWG Test Board	9
CST Model	9
Simulation Results	9
Improving Match	10
Determination of the Optimal Launch – Taper (Version 1)	10
0.020" Taper Simulation Results	10
Optimized Taper (Version 2)	11
0.033" Taper Simulation Results	11
Improving Bandwidth	12
Bandwidth is Related to Via Spacing	12
Channelized Coplanar Waveguide	12
Purpose of the Vias	12
Realization of Lateral Walls by Closely Spaced Vias	12
Analysis of the Test Boards	13
Analysis of the Original Test Board	13
Analysis of Test Board with 3 Vias	14
Analysis of Test Board with 7 Vias	14
Analysis of Test Board with 13 Vias	15
Analysis of Test Board with 25 Vias	15
Analysis of Wider Row Spacing (126 mils)	16
Analysis of Closer Row Spacing (98 mils)	17
Putting it All Together	18
1. Original GCPWG Test Board (2003)	18
2. Reproduction of Original Test Board (2007)	18
3. Tapered Trace to Improve Match	19
4. Closer Vias to Improve Bandwidth	19
Loss Comparison	20
Loss (Straight Microstrip, Top Ground Microstrip, and GCPWG)	20
1" Straight Microstrip Test Board	20
2.5" Straight Microstrip Test Board	21
1" Top Ground Microstrip Test Board	22
2.5" Top Ground Microstrip Test Board	23
1" GCPWG Test Board	24
2.5" GCPWG Microstrip Test Board	25
1" & 2.5" Test Boards Results Compared	26
Loss Summary	28
Appendix A: Test Boards (Variables and Results)	28



Test Equipment and Techniques

An Agilent 8510D network analyzer was used for most of the published measurements (in the loss section an Agilent PNA was used). The test port connectors used were 2.4 mm connectors and the frequency range for all measurements was DC to 50 GHz. Calibration was a full 12-term SOLT calibration with sliding loads. The TDR measurements were set up as low pass step in real units. All of the data was taken from the same calibration. Some internal verification of data was done on an Anritsu 37297 network analyzer.

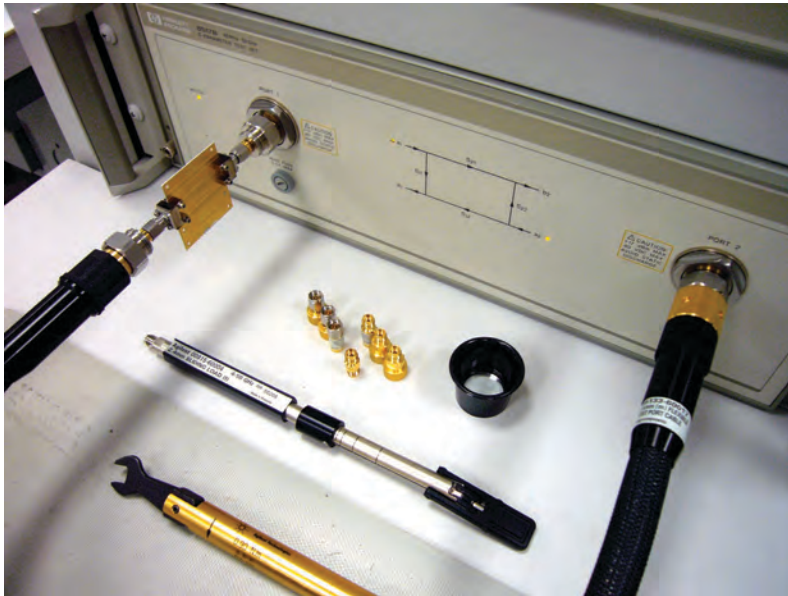

Analyzer Workstation (HP 8510C)

- ▶ 12-term SOLT calibration.
- ▶ Sliding loads were used.
- ▶ Single cable – DUT connected directly to port 1.
- ▶ Non-insertable handled by swapping phase matched adapters.
- ▶ 201 points.
- ▶ Harmonic sweep for time domain.

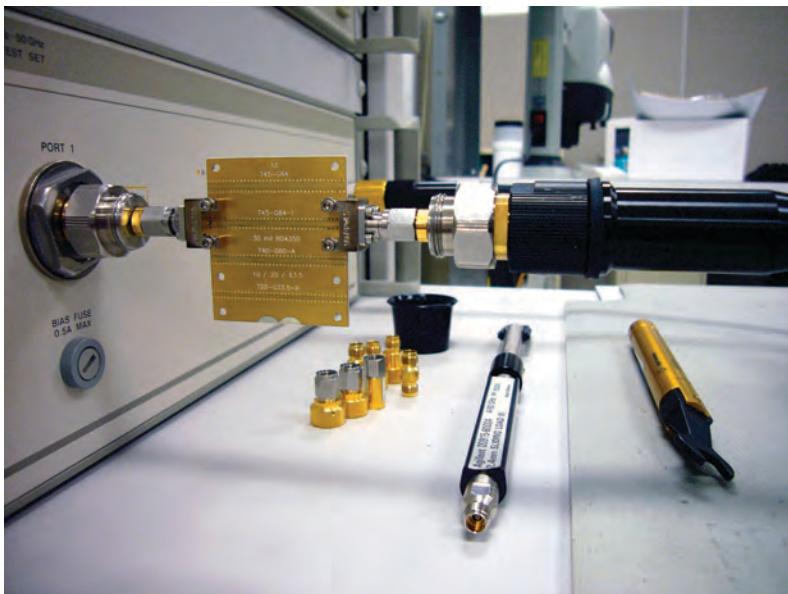



Southwest Microwave Standard S-Parameter Plot

SMI Standard Format of S-Parameter Data

S-parameter data: The format of the data is S11 on the bottom of the graph in VSWR with scale of 0.2 per division, and S21 on the top of the graph in Log Mag with a scale of 1 dB per division.

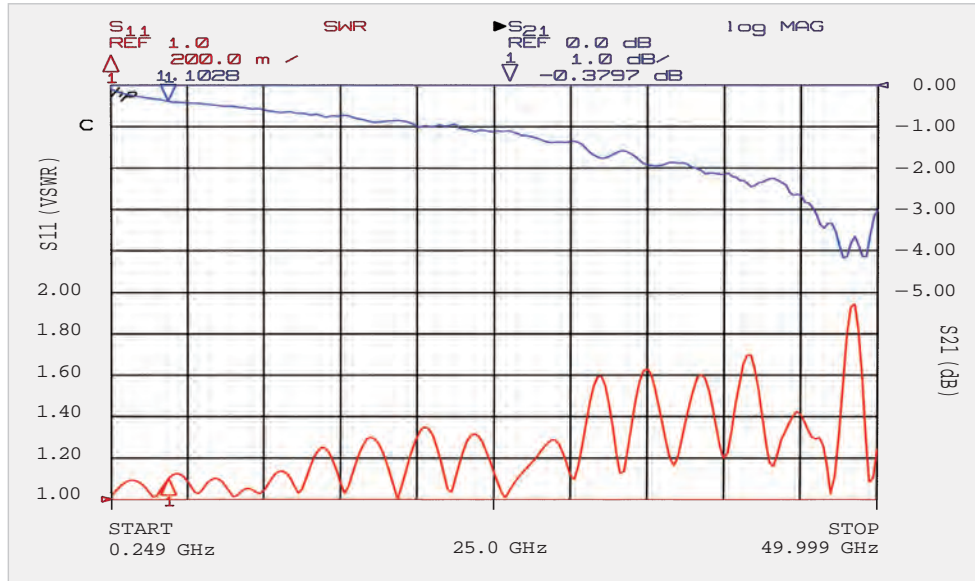

Test data original 30 mil GCPWG test board (Serial Number Ø).

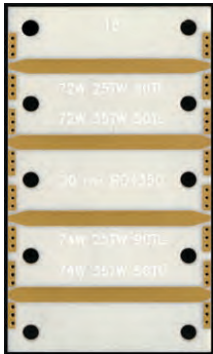

Microstrip Board

Purpose

For many years Southwest Microwave, Inc. has manufactured field replaceable connectors and launch accessories where connector performance was easily verified by measuring two connectors back-to-back as a two-port device. The responsibility for packaging and board layout fell to the user to develop independently.

With the introduction and success of Southwest Microwave end launch connectors, the packaging responsibility has fallen to SMI; the user is now only responsible for board layouts. To assure maximum performance of the SMI end launch connectors, equally high performance test boards were needed to accurately measure the connectors. In the pursuit of high performance test boards, it was decided to broaden the research project and begin a comprehensive study of board layout design variables and their effects on microwave performance.

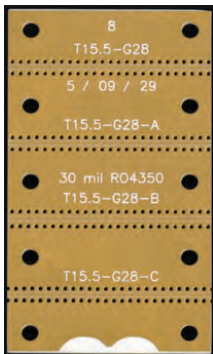

GCPWG Board

Scope of the Evaluation

This evaluation explores transitions of grounded coplanar waveguide (GCPWG) and microstrip lines to coaxial connectors with the use of SMI end launch connectors. The baseline for the GCPWG portion of this study is an older board design that worked reasonably well to 45 GHz. The use of 3-D simulation was included in this evaluation.

The mechanics of the layouts were done by a consultant (Petra Microwave) and the boards were fabricated by Accurate Circuit Engineering in Southern California. The material was supplied as samples by Rogers Corp.

Straight microstrip test board 15c,
30 mil R04350, S/N = 51,
(with actual test results).

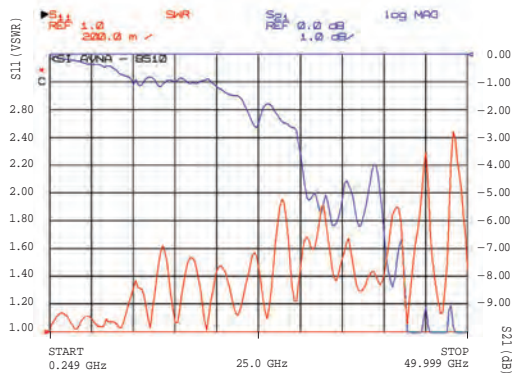

Top ground launch microstrip test board 14c, 30 mil R04350, S/N = 52,
(with actual test results).

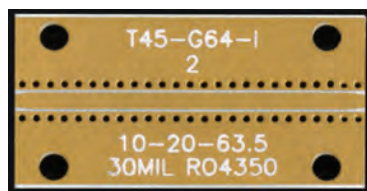
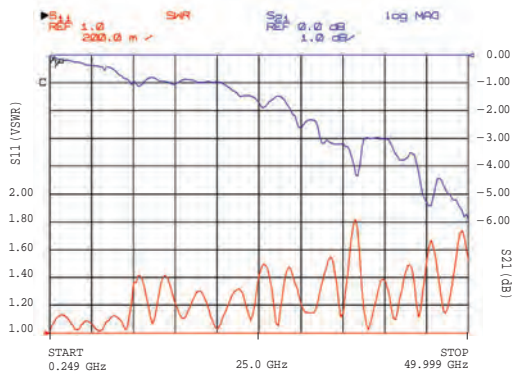

Best performing coplanar test board 2,
(30 mil R04350), S/N = 10, Trace = 45,
Ground = 64.

Comparison of GCPWG and Microstrip

This study was conducted by (SMI) to evaluate grounded coplanar waveguide (GCPWG) launches and lines, top ground (coplanar) launches to microstrip lines, and microstrip lines running straight to the edge of the board on 30 mil Rogers 4350 boards.

Microstrip structures on substrates this thick (0.030") have many drawbacks. There is the effect of dispersion which changes the impedance of the line over frequency. There is also significant radiated loss from microstrip at frequencies above 30 GHz. Another drawback is the line widths are much wider than a coaxial line which would match the board thickness because of the low dielectric constant of these materials, so either an overly large coaxial is used or the microstrip line has to be tapered and matched properly to the coax. Microstrip does have an advantage in line loss.

Shown here are the results of one microstrip line straight to the edge and another with a top ground launch. These represented the best of their types of over 30 lines and launches that were tested. It can be seen in this data that above 30 GHz the slope of the loss increases, showing where radiated loss starts to dominate. Without the top ground the performance of the board at frequencies over 30 GHz degrades rapidly.

GCPWG addresses these drawbacks. The impedance is more stable over frequency. When the ground vias are properly implemented there is a great reduction in radiated loss. And with GCPWG, where the geometry is arbitrary, there is the ability to choose line and ground widths that better match a coax line.

Final Test Results

Shown here is the final GCPWG structure. The next few sections of this paper will show how the details of the launch geometry (trace taper) and the correct via placement were worked out. This final result shows that GCPWG can create boards with much higher frequency performance than what microstrip may be limited to on the same material.

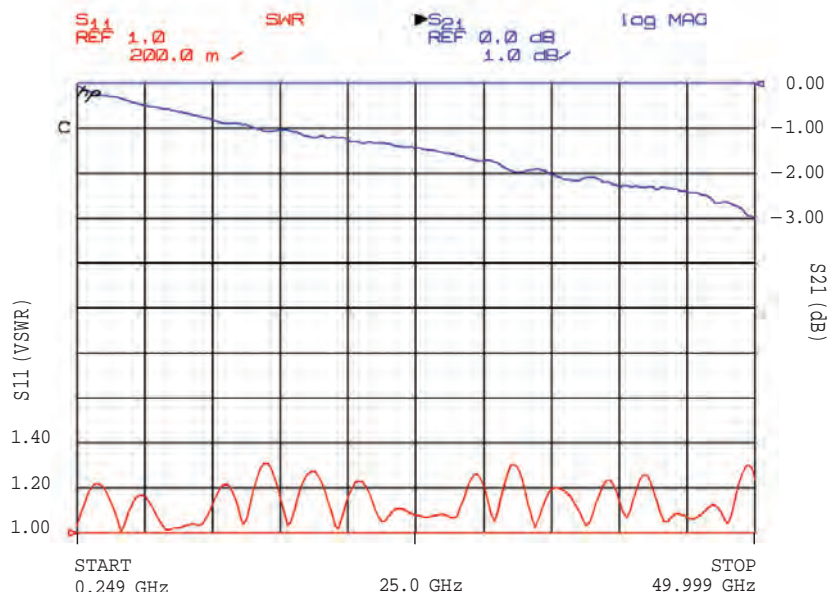

Actual test results from board 2 (Serial Number 10).

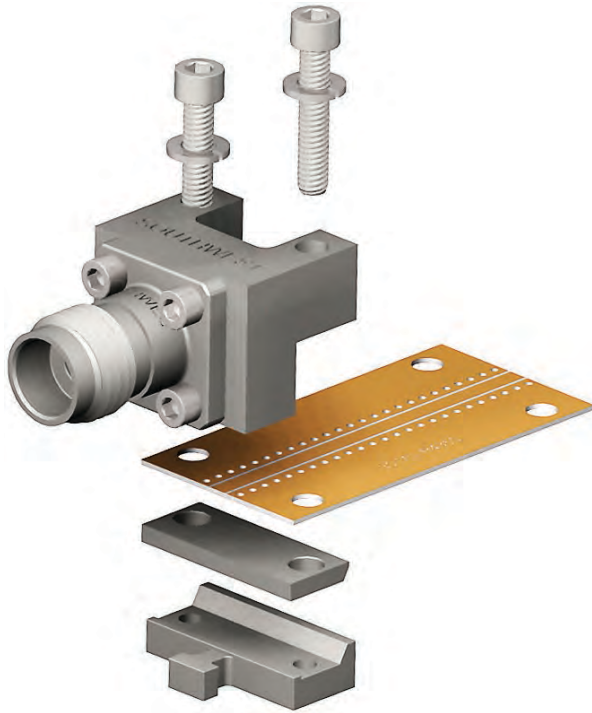

End Launch Connector Features:

- ▶ Southwest Microwave end Launch connector assemblies, model number 1492-02A-5.
- ▶ Used on single-layer boards.
- ▶ Used on multi-layer boards where the top layer is the microwave layer.
- ▶ No soldering is needed.
- ▶ Usable with any board thickness.

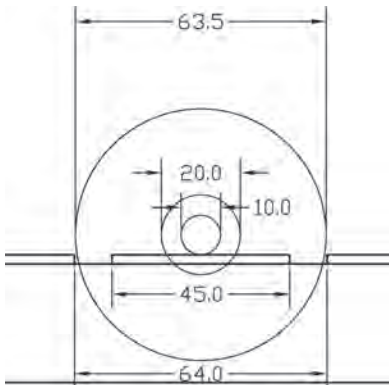

The layout configuration for the 30 mil R04350 coplanar test board and connector.

Review of Original Test Board (2003)

When the end launch connectors were first introduced in 2003, a one-inch long GCPWG test board was developed for testing. One of these original test boards was used in this study to establish the baseline performance of the connectors.

Below are the results of the original end launch connector test board and a drawing of the board. The data shows the characteristic glitch in the loss starting at 45 GHz that is characteristic of this board.

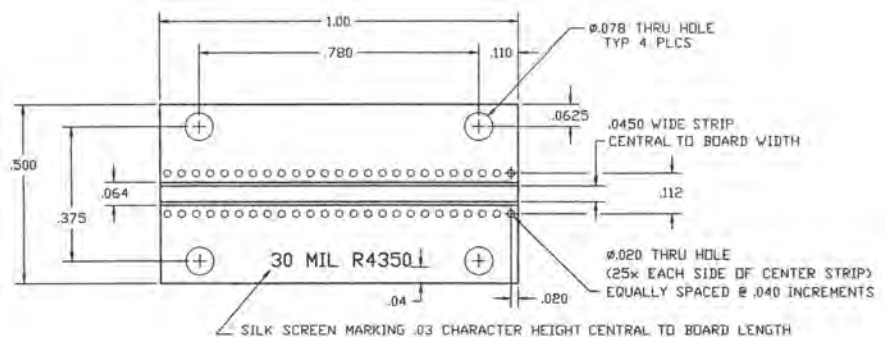

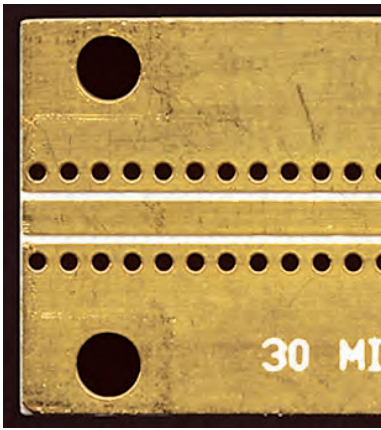

Board Ø (2003)
Original 30 mil coplanar test board.



Board Ø (2003)
Serial Number = Ø
Trace = 0.045"
Ground = 0.064"
Via Size = 0.020"
Via Spacing = 0.040"
Via Rows = 0.112"
Fabricated = 2003

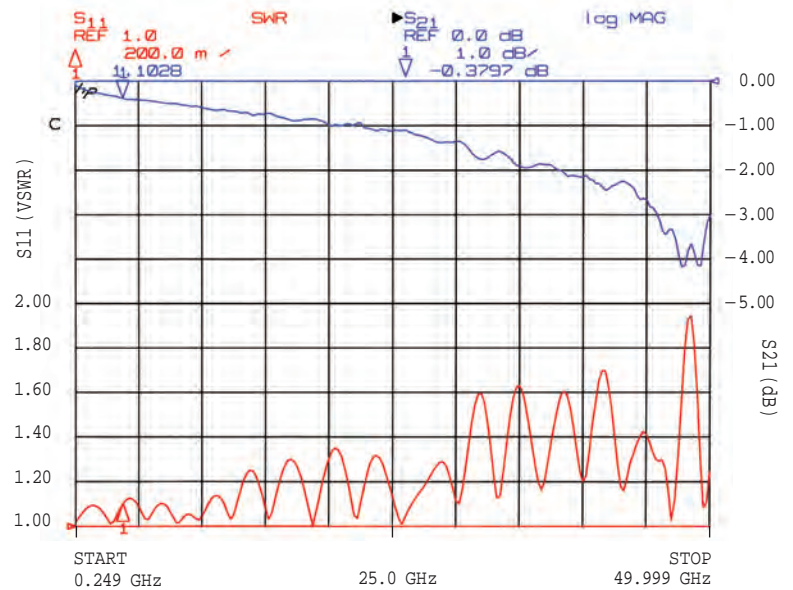
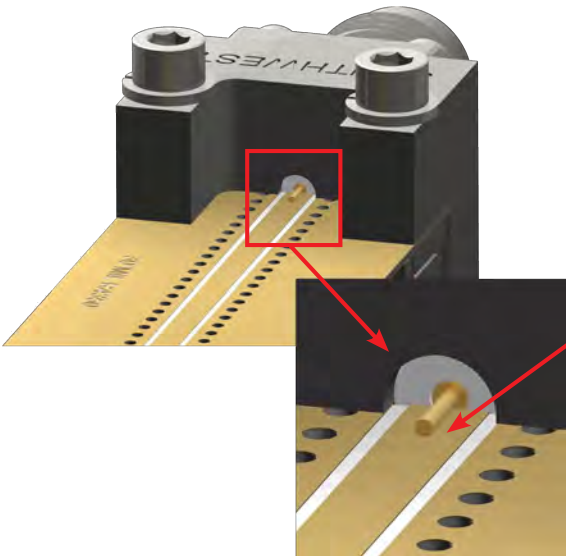

Test data original 30 mil coplanar test board (Serial Number Ø).

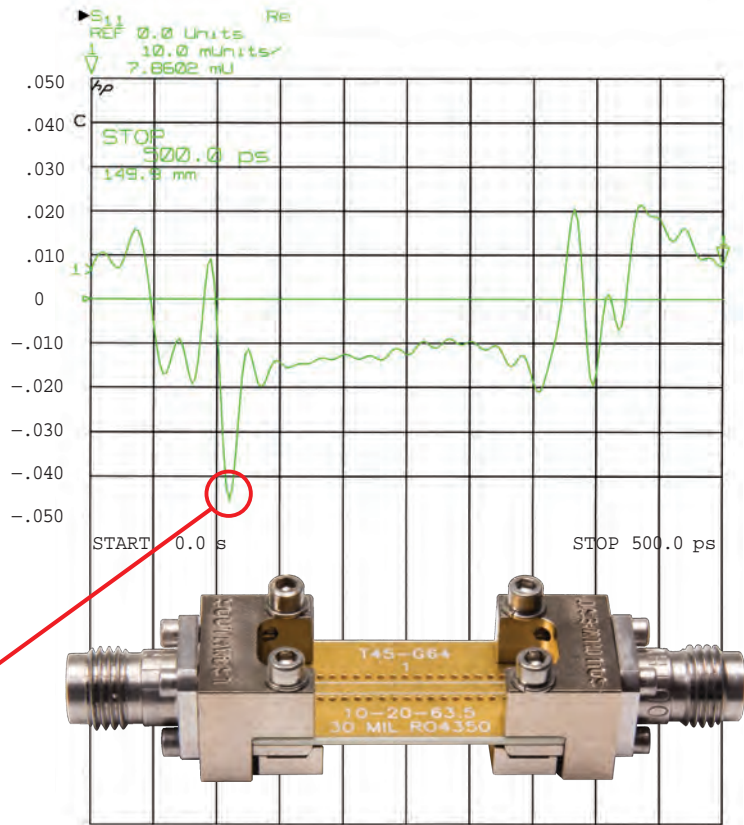

TDR of original coplanar test board (Serial Number Ø).

Time Domain (TDR) Test Data

The TDR data is in real units over time. It shows the discontinuity at the launch and the impedance of the board.

Reproduction of Original Test Board (2007)

This reproduction was fabricated in the same lot in 2007 as the test boards used in the rest of this study. The purpose is to tie the results of this lot of boards to the results from the original test board fabricated in 2003.

Below are the results of the reproduction of the original test board. The results are very similar to the original board including the glitch in the insertion loss at 45 GHz.

The VSWR slowly rises through 45 GHz to 1.6:1 as on the original board.

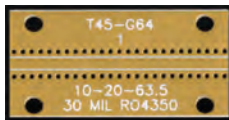

Board 1 (2007)
 Serial Number = 19
 Trace = 0.045"
 Ground = 0.064"
 Via Size = 0.020"
 Via Spacing = 0.040"
 Via Rows = 0.112"
 Fabricated = 2007

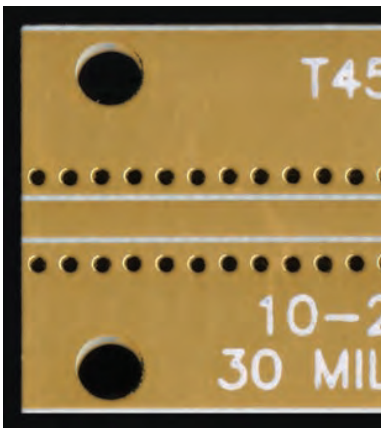

Board 1 (2007)
 A reproduction of the original 30 mil coplanar test board.

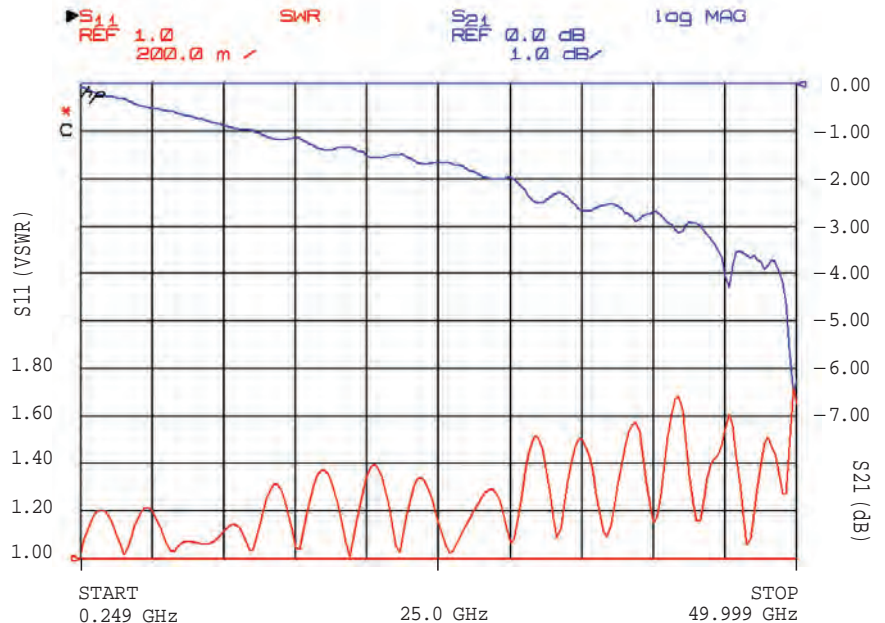

Test data for reproduction of original 30 mil coplanar test board
 (Serial Number 19).

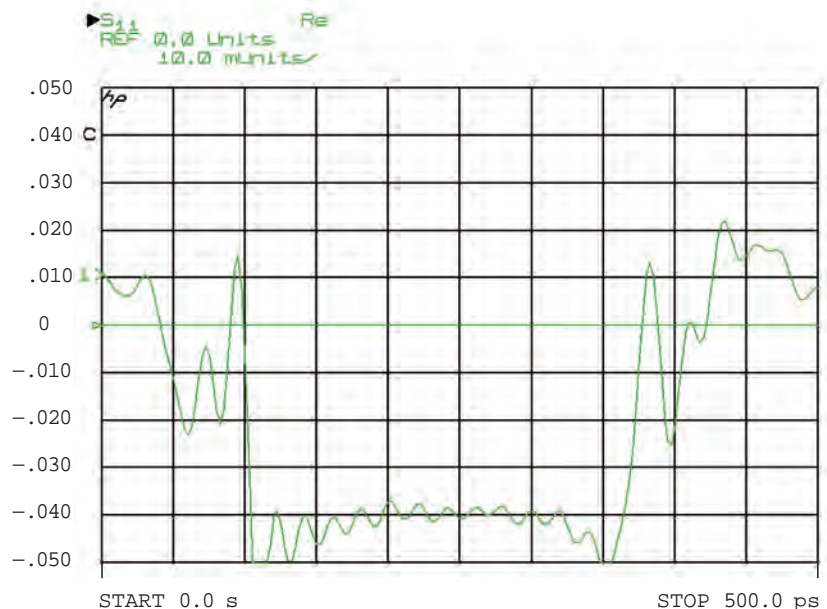

Actual time domain (TDR) test board data (Serial Number 19).

3-D Simulation (Original GCPWG Test Board)

Simulation can be used to predict results of these types of structures then changes are made and the results of that change are viewed without having to fabricate and test actual hardware. Decent correlation of the known performance of this test board was achieved with CST Microwave Studio® (CST MWS) Simulation. CST provided the simulations.

**CST MWS Model
Without
Connectors**

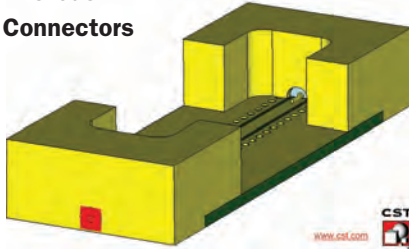

CST MWS Model

The 3-D simulation model is created by only looking at the transition blocks and the test board. The biggest discontinuity in the transmission line is the transition from coax to PCB. The worst transmission line is the PCB. The two coaxial connectors are well matched and have very low loss, so even without them in the simulation, a very good correlation to the actual performance can be achieved.

TDR

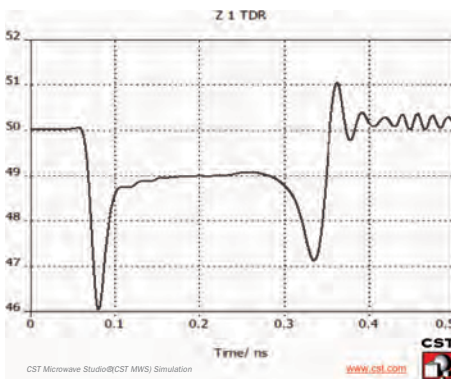

The TDR shows the board impedance below 50 ohms and a capacitive dip on either end where the launch pin sits on the board. This also corresponds to measured data.

Simulation Results

The insertion loss has a dip at 45 GHz and the VSWR slowly rises over frequency from below 1.2:1 to 1.6:1 through 45 GHz. Both of these are characteristic of the test board and show good correlation of simulated to measured.

Original Test Board Simulation & Actual Test Data S-Parameter Data / VSWR

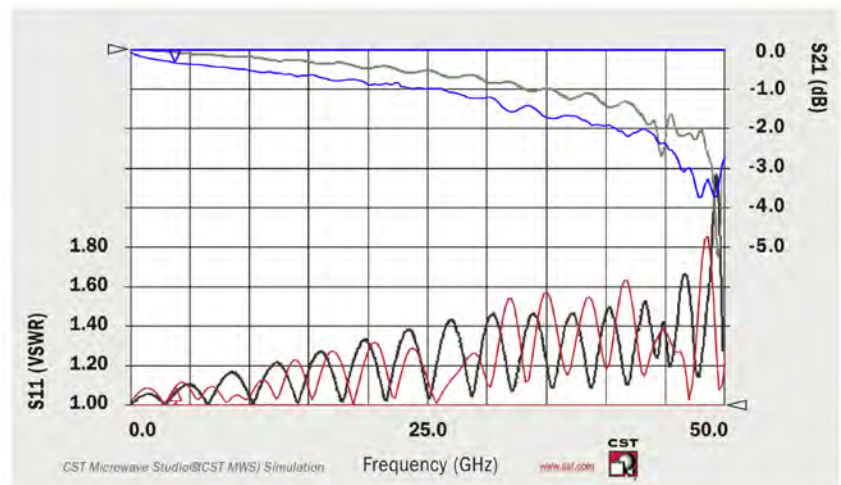

Simulation of original test board (shown in black & gray), **compared to actual measured data** (shown in red & blue).

Improving Match

Determination of the Optimal Launch – Taper (Version 1)

At the end of the board where the launch from the board's microwave transmission structure, to a coaxial line occurs there is a pin from the coax sitting on top of the board. This added metal creates an increase in capacitance that has to be addressed for optimal performance. The way to compensate for the capacitance of the pin is to add inductance to the board. This can be done in both microstrip and grounded coplanar waveguide (GCPWG) by narrowing the trace. The method used here is reducing the trace, what is referred to as a taper.

This is the first study where the taper of GCPWG is examined in detail. The traditional way a taper was determined was to match the width of the trace with the coax launch pin, then taper it out to the proper microstrip width over the distance that the pin sits on the line. It has been shown in earlier test boards that this may be over-compensating for the capacitance, so the CST MWS 3-D model was again used to get a prediction.

Taper (version 1)



Taper (version 1)

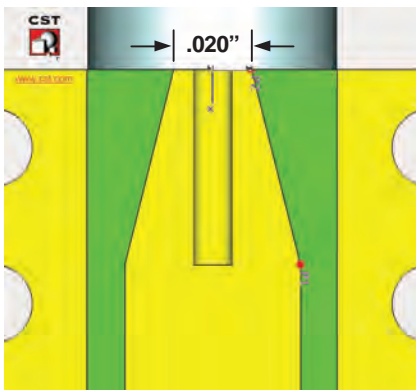

The S-Parameter results of the CST MWS model of the first taper design shows that it actually makes a worse match than no taper at all and causes ripple in the insertion loss. The TDR results of the simulation shows that even with the pin the circuit is too inductive right at the launch.

Comparison: Taper (version 1), and No Taper

TDR

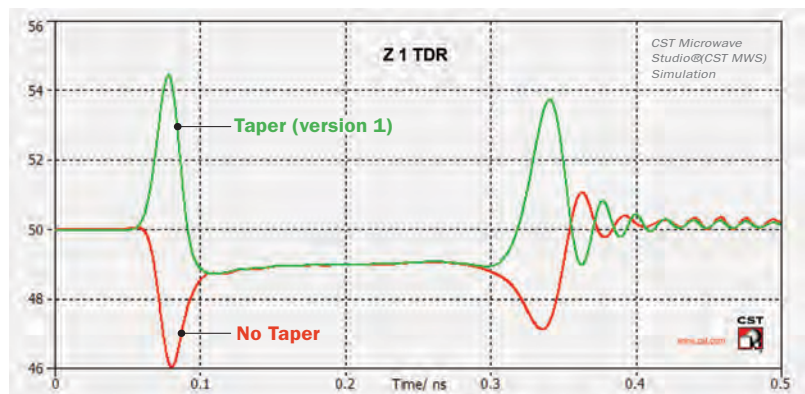

Taper (version 1)

Simulated S-Parameter Data / VSWR

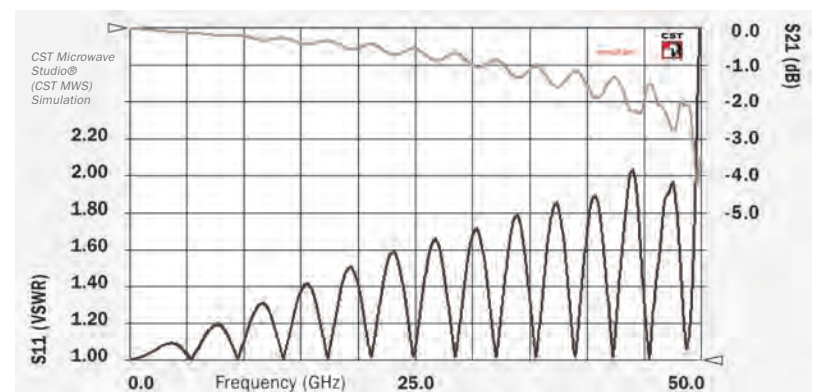

Optimized Taper (Version 2)

The second taper design was developed using CST Microwave Studio's optimization routine. The taper length was kept the same, but the final dimension at the edge of the board was increased. This still adds some inductance to the board right at the launch, but it is less inductive than the first taper design. The simulation results show excellent results for S11, much better than could be realized in practice and the insertion loss is very smooth up to the normal 45 GHz glitch always seen.

Optimized taper (version 2)



Optimized taper (version 2)

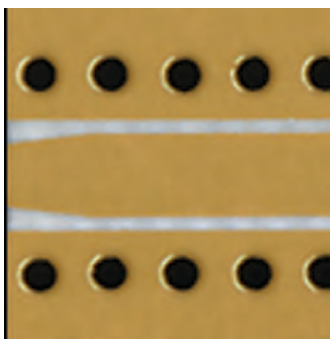
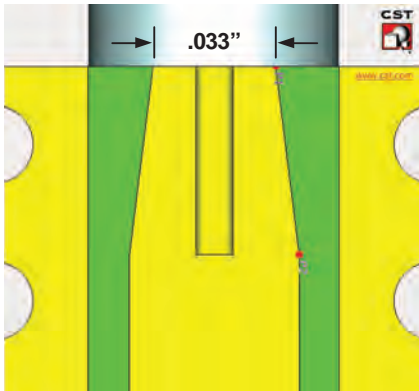

Enlarged view of coplanar test board 5d, Serial Number = 32, Trace = 45, Ground = 64

Comparison: Taper (version 1), Optimized taper (version 2), No Taper TDR

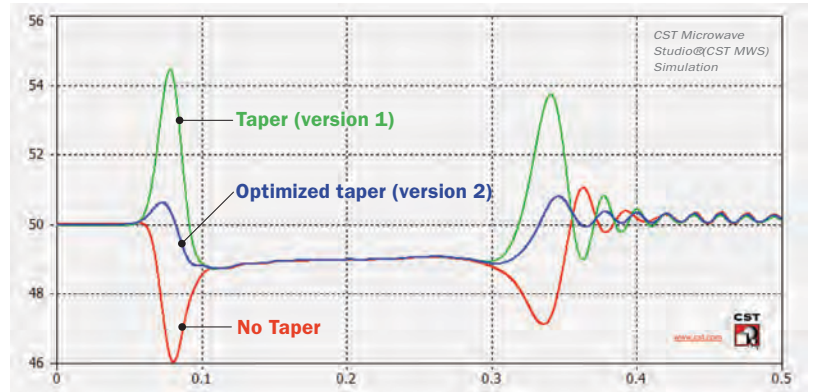

Optimized taper (version 2)

Simulated S-Parameter Data / VSWR

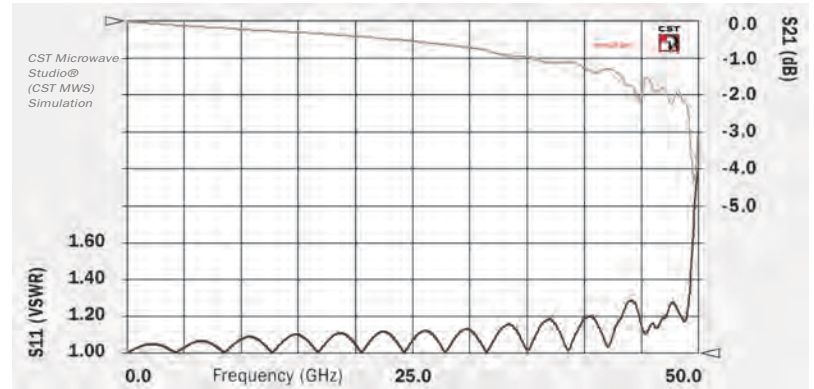

Actual Test Data for 30 mil Coplanar Board 5d (Serial Number 32).

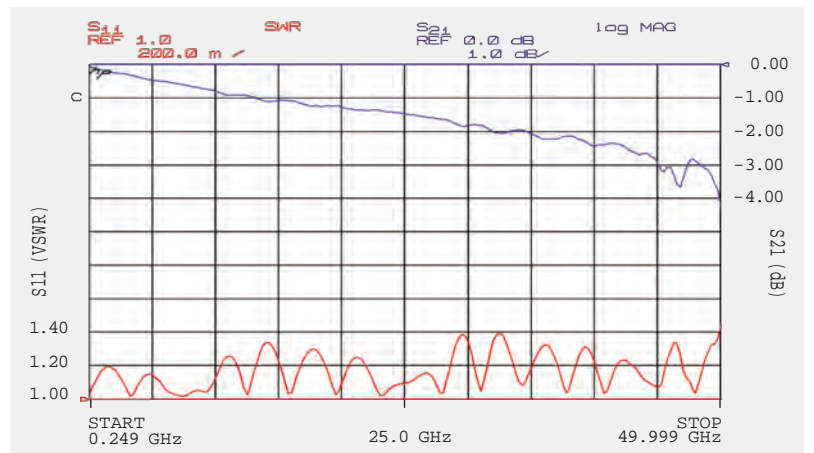

Improving Bandwidth

Bandwidth is Related to Via Spacing

Channelized Coplanar Waveguide ¹

While doing research into proper via placement, a reference to “channelized coplanar waveguide” was found that explained the function of the vias as it related to bandwidth. Channelized coplanar waveguide is a GCPWG structure with lateral walls that create another waveguide mode and stops surface wave inside the structure from being created.

Purpose of the Vias

Once it was determined that placing lateral walls would increase the bandwidth of the circuit and that the vias were acting as a microwave wall, the spacing of the vias became more predictable. In general, microwave energy will reflect from openings less than a quarter wavelength of the signal.

The other determining factor in the high frequency performance of the vias is the spacing between the rows of the vias. The wider the spacing, the lower the cutoff frequency and the closer the spacing the higher the cutoff frequency.

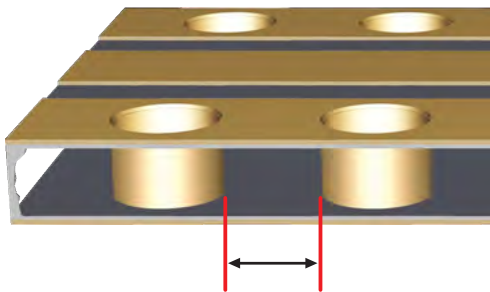
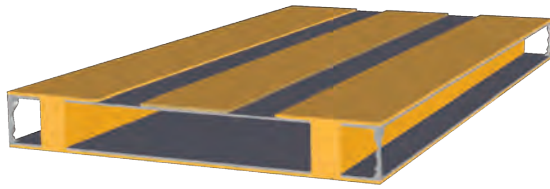

3-D illustrations of conductor-backed, channelized coplanar waveguide (CCPW).

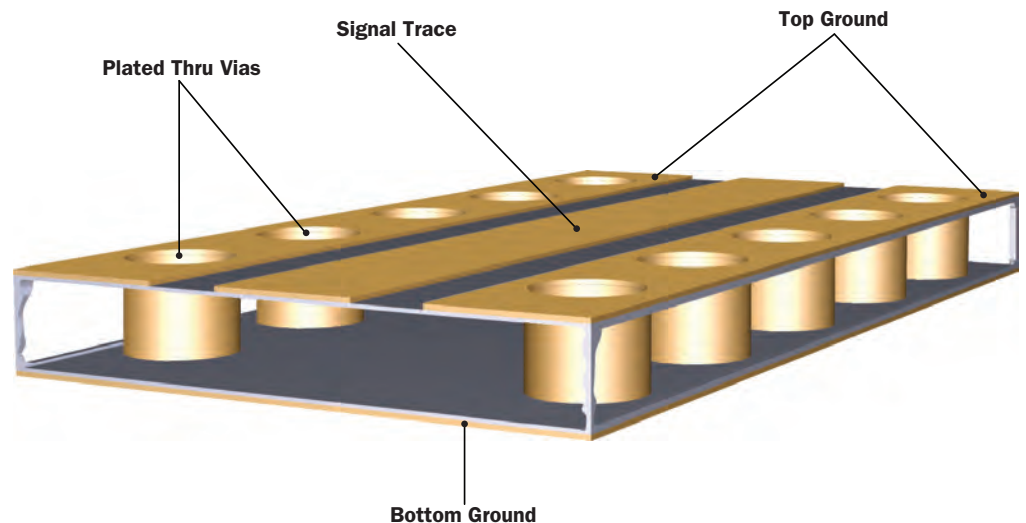

Realization of Lateral Walls by Closely Spaced Vias

The illustration above shows the Grounded Coplanar Waveguide (GCPWG) used for these test boards. Rows of plated through vias are used to tie the top ground planes to the bottom ground plane, simulating a wall as shown in shadow between the vias (see illustration on left).

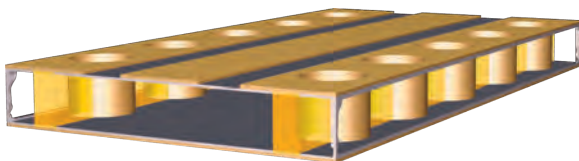

1. (Reference) Rainee N. Simons, “Coplanar Waveguide Circuits, Components, and Systems” Wiley-Interscience, A John Wiley & Sons Inc., Publication, New York, NY, 2001.

Analysis of the Test Boards

Analysis of Original Board

The original test board shows VSWR gently increasing over frequency through 50 GHz. This increase in VSWR is due to the match and as seen in the previous section can be addressed by introducing a taper at the launch.

The insertion loss is fairly smooth until 45 GHz. The reason for the glitch at 45 GHz most likely is a function of the vias which will be investigated in this section. The original test board has 25 vias of 0.020" in diameter and equally spaced at 0.040" centers. Since the purpose of the vias is to create a "wall" the important dimension of the vias is the space between the vias, or the dimension from the edge of one via to the edge of the next via. For this board the spacing is 0.029" which in R04350 with a dielectric constant of 3.66 corresponds to a frequency of 53 GHz.

The via rows spacing is 0.112" and is also a determinant in the performance of the board. Again, closer spacing should lead to higher frequency operation.

1.000	Board Length
-0.020	Distance from Edge (2)
-0.040	Diameter (2)
<hr/>	
.940	
÷ 24	(25) Vias - (24) Spaces
<hr/>	
0.039	
-0.010	Radius of Middle Via
<hr/>	
0.029"	Gaps → 53 GHz ($\frac{1}{4} \lambda$ in R04350)

Original Test Board (25 Vias)



Board Ø (2003)
Serial Number = Ø

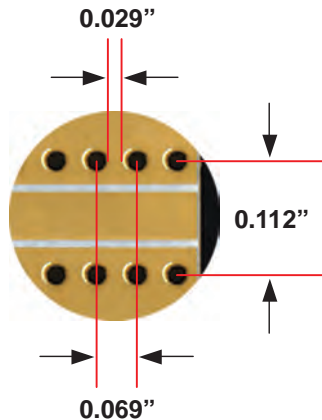

Board detail (25 vias)

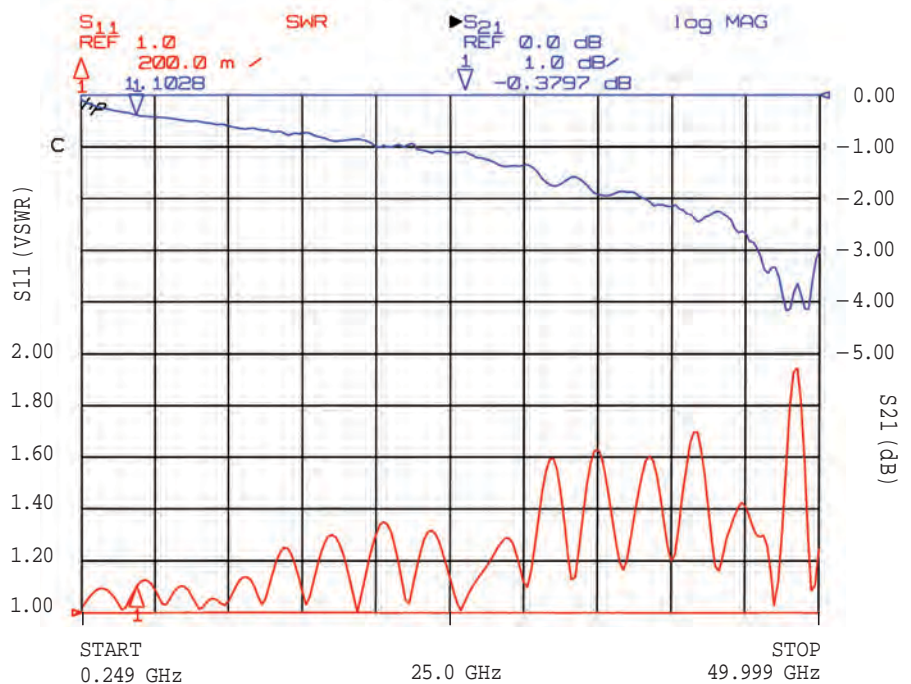

Original board test results through 50 GHz.

Analysis of Test Board with 3 Vias

With only 3 vias on a one-inch board, the spacing between the vias is 0.460". The quarter wavelength frequency in RO4350 is 3 GHz. The board operates without any glitches to 5 GHz so there is some correlation shown.

3 Via Rows

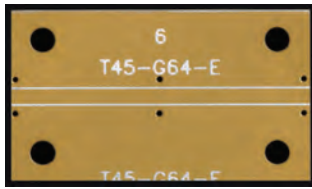

Board 6a S/N = 34

Board detail (3 vias)

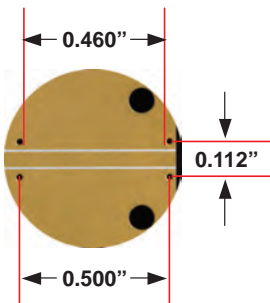

0.460" Gaps → 3 GHz ($\frac{1}{4} \lambda$ in RO4350)

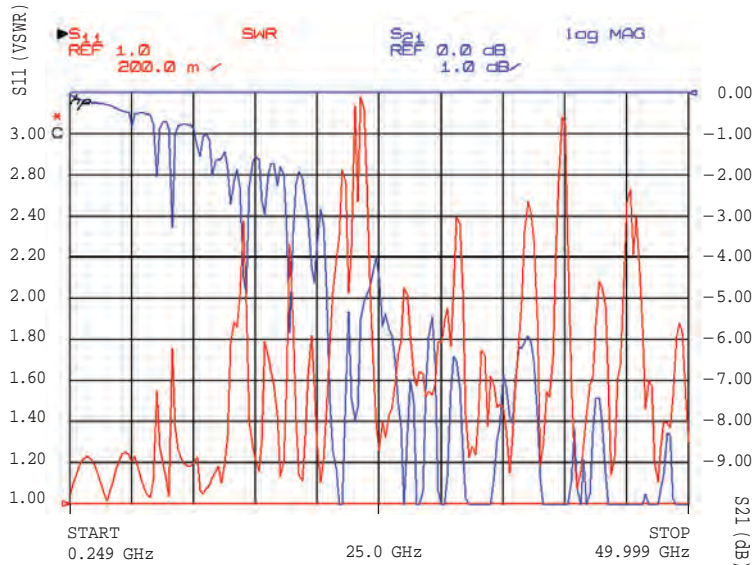

Actual test results using 3 vias without taper through 50 GHz.

Analysis of Test Board with 7 Vias

With 7 vias on a one-inch board, the spacing between the vias is 0.146". The quarter wavelength frequency in RO4350 is 11 GHz. The board operates without any glitches to 13 GHz so there is more correlation shown and a clear improvement as the spacing between the vias is decreased.

7 Vias Test Board

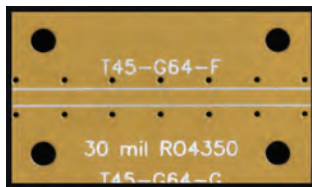

Board 6b S/N = 34

Board detail (7 vias)

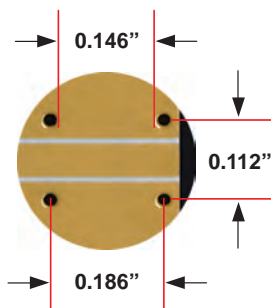

0.146" Gaps → 11 GHz ($\frac{1}{4} \lambda$ in RO4350)

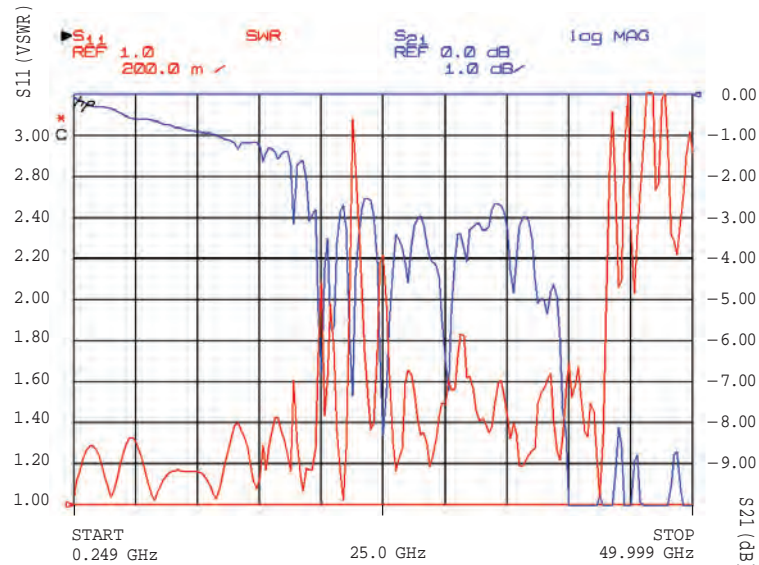

Actual test results using 7 vias without taper through 50 GHz.

Analysis of Test Board with 13 Vias

With 13 vias on a one-inch board, the spacing between the vias is 0.0683". The quarter wavelength frequency in R04350 is 23 GHz. The board operates without any drastic glitches to 35 GHz so there is even more correlation shown and a clear improvement as the spacing between the vias is decreased.

13 Vias Test Board

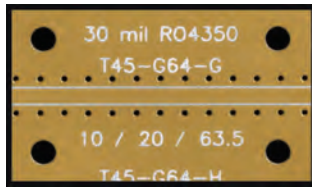

Board 6c S/N = 34

Board detail (13 vias)

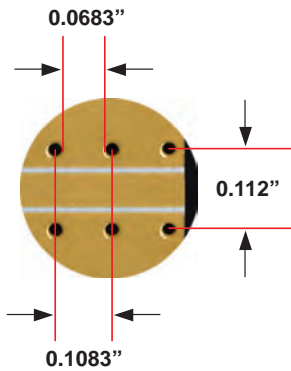

0.0683" Gaps → 23 GHz ($\frac{1}{4} \lambda$ in R04350)

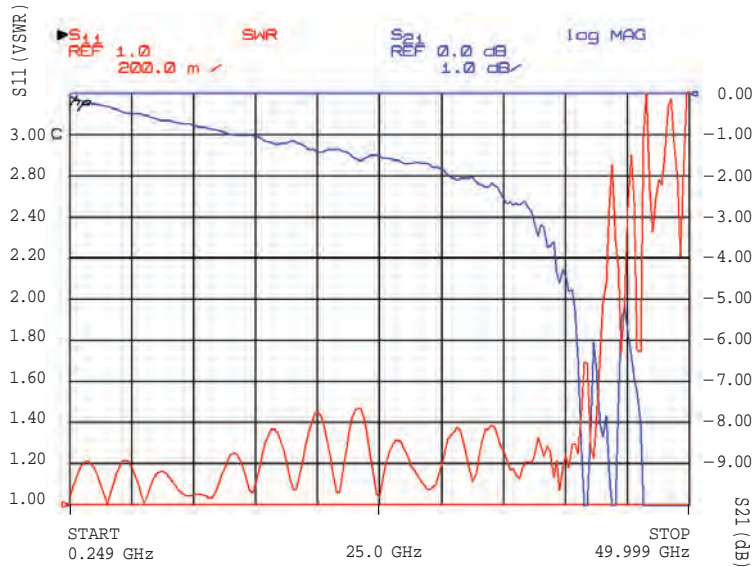

Actual test results using 13 vias without taper through 50 GHz.

Analysis of Test Board with 25 Vias

This is the reproduction of the original test board. It has been seen in the previous boards that they will work somewhat above the quarter wavelength frequency so this board should work easily to 50 GHz. There is still the glitch at 45 GHz so there must be some other factor involved.

25 Vias Test Board

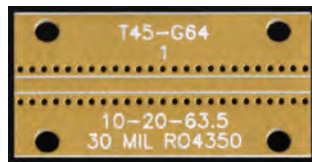

Board 1 (2007)

Board detail (25 vias)

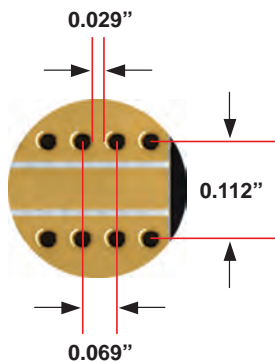

0.029" Gaps → 53 GHz ($\frac{1}{4} \lambda$ in R04350)

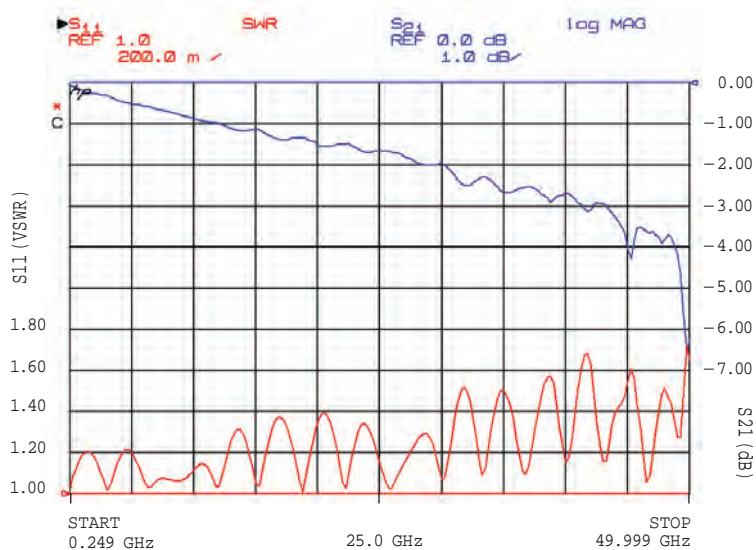

Actual test results using 25 vias without taper through 50 GHz.

Analysis of Wider Row Spacing (126 mils)

It has been speculated that making the rows closer will increase the bandwidth of the board. To determine the effect of the row spacing a board was made where the rows were moved out to 0.126" from the original 0.112".

Wider Spaced Via Rows

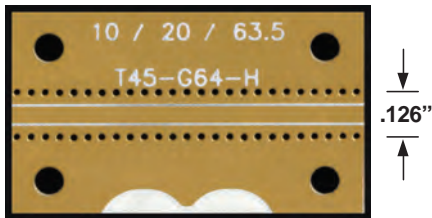

Board 6d
Serial Number = 34

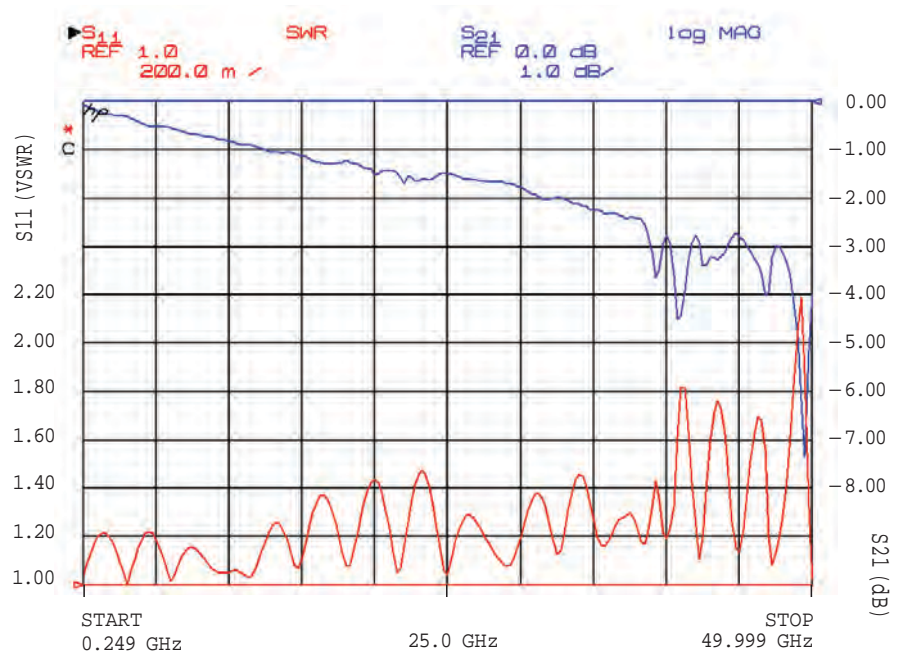

Actual test results for wider spaced via rows.

Analysis of Closer Row Spacing (98 mils)

The original test board had a spacing from the centers of the rows of 0.112". A reduction of this spacing should increase the frequency response of the board. A distance of 0.098" was chosen as it was the closest spacing to the coplanar structure that could be achieved in normal board manufacturing processes.

The data from the test board with a 0.098" spacing confirms the increased bandwidth of the board and the loss curve is smooth through 50 GHz.

Closer Via Row Spacing

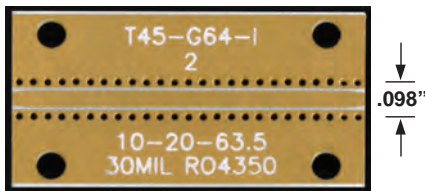

Board 2
Serial Number = 10

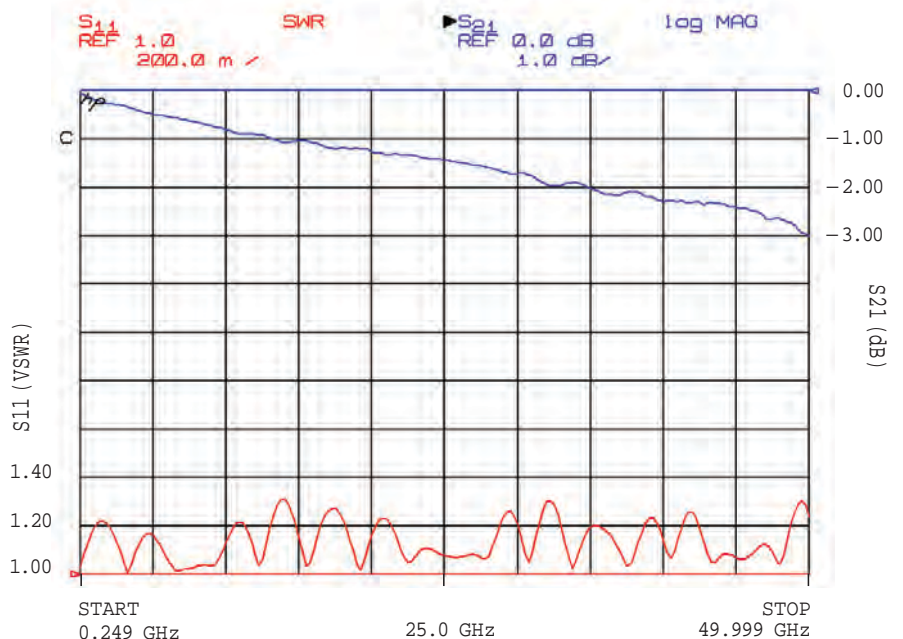

Actual test results using 25 vias through 50 GHz.

Putting It All Together

1. Original GCPWG Test Board (2003)

This is the original 30 mil grounded coplanar waveguide test board fabricated in 2003 as the end launch connector line was first introduced. There are only a few boards left here from that original lot and one has been the baseline for this study.



Board Ø (2003)
Original test board (25 vias)
Serial Number = Ø

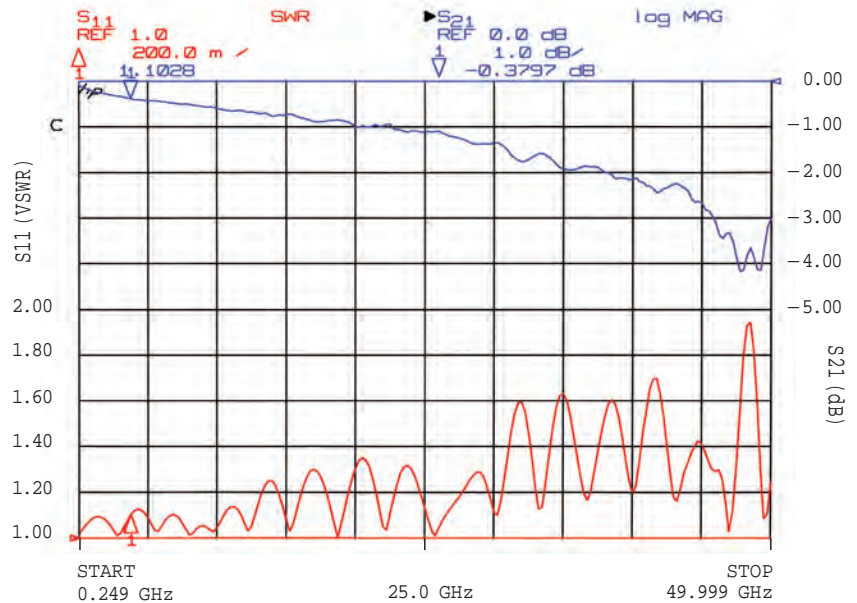

Test data original 30 mil coplanar test board (Serial Number Ø).

2. Reproduction of Original Test Board (2007)

The first step in this study was to duplicate the original test board so there was verification that this lot of boards would be similar in performance.

The data shows that this board fabricated in 2007 is very similar in performance to the original board from 2003.

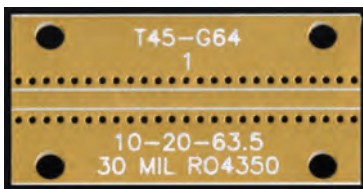

Board 1 (2007)
Reproduction of original
test board (25 vias)
Serial Number = 19

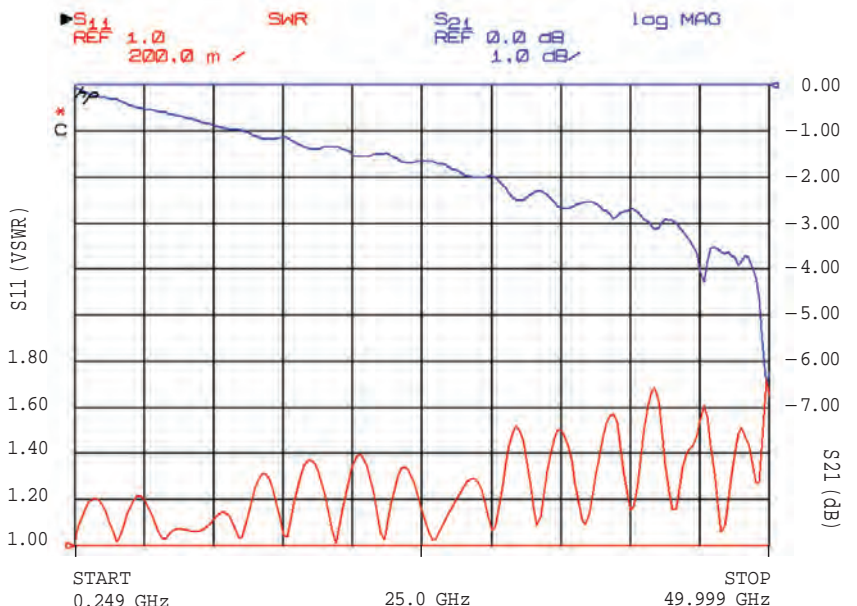

Test data for reproduction of original 30 mil coplanar test board
(Serial Number 19).

Putting It All Together

3. Tapered Trace to Improve Match

The first issue addressed was optimizing the launch. The trace was tapered to add inductance to the board to compensate for the added capacitance of the connector pin. Simulation was used to optimize the taper. Measurement of test board confirms that the match is improved as seen in the reduced VSWR through 50 GHz.

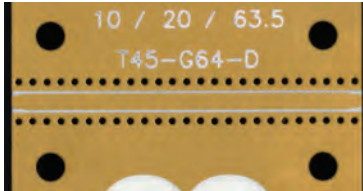

Board 5d

Improving match (using a taper)

Serial Number = 32

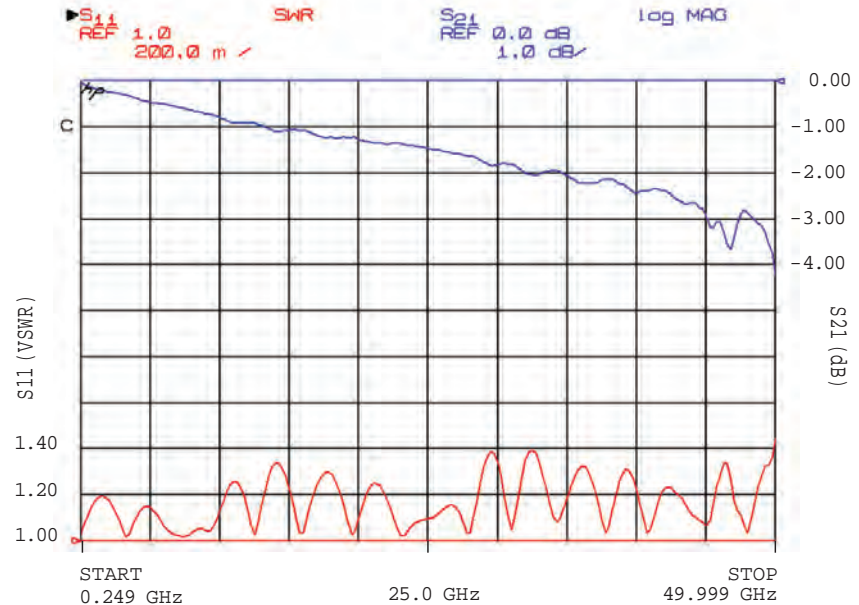

Actual test data for 30 mil coplanar board 5d (Serial Number 32).

4. Closer Vias to Improve Bandwidth

After understanding the function of the vias, it was determined that the number and size of the vias of the original board were enough for 50 GHz of bandwidth. The spacing of the rows of vias had to be moved closer together to increase the bandwidth. Measurement of the final board confirms that the bandwidth was increased through 50 GHz as indicated by the smoothness of the insertion loss curve.

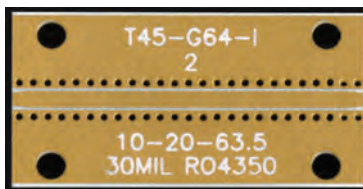

Board 2

Improving bandwidth
(proper via placement)

Serial Number = 10

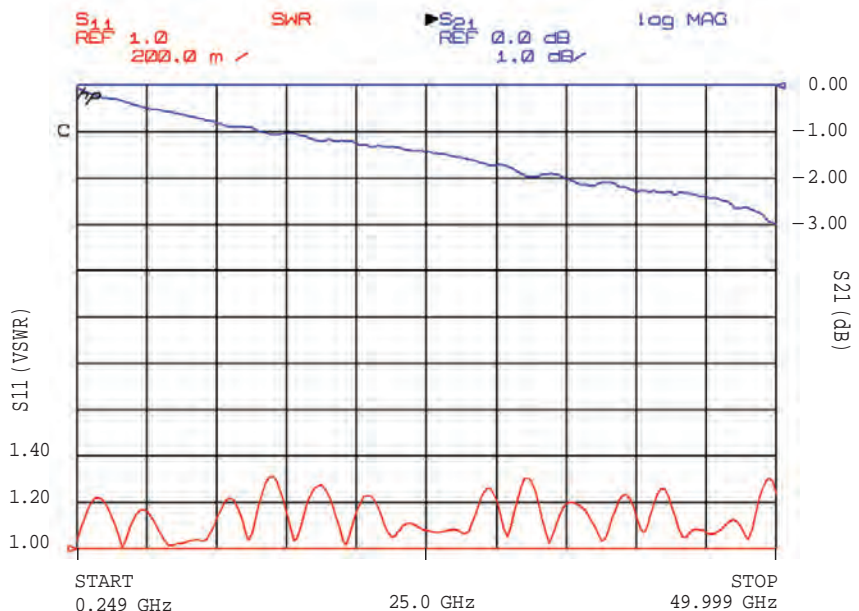

Actual test data for 30 mil coplanar board 2 (Serial Number 10).

Loss Comparison

Loss (1" Straight Microstrip Test Board 15c – S/N 51)

This data shows how microstrip straight to the edge of the board on 30 mil RO4350 has 2 distinct slopes depending on frequency. The low frequency loss is dominated by board loss and the high frequency loss is dominated by radiated loss. To calculate board loss the low frequency region should be used.

← 1" →

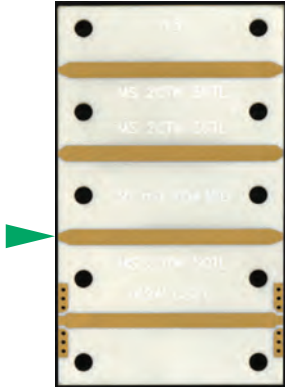

Straight Microstrip			
	Board 15c	Loss/Inch	Loss/Launch
5 GHz	0.3	0.1	0.1
10 GHz	0.6	0.2	0.2
15 GHz	0.9	0.3	0.3
20 GHz	1.2	0.4	0.4
25 GHz	1.5	0.5	0.5
30 GHz	3.3	0.7	1.3
35 GHz	5.5	0.9	2.3
40 GHz	7.7	1.1	3.3
45 GHz	9.9	1.3	4.3
50 GHz	12.1	1.5	5.3

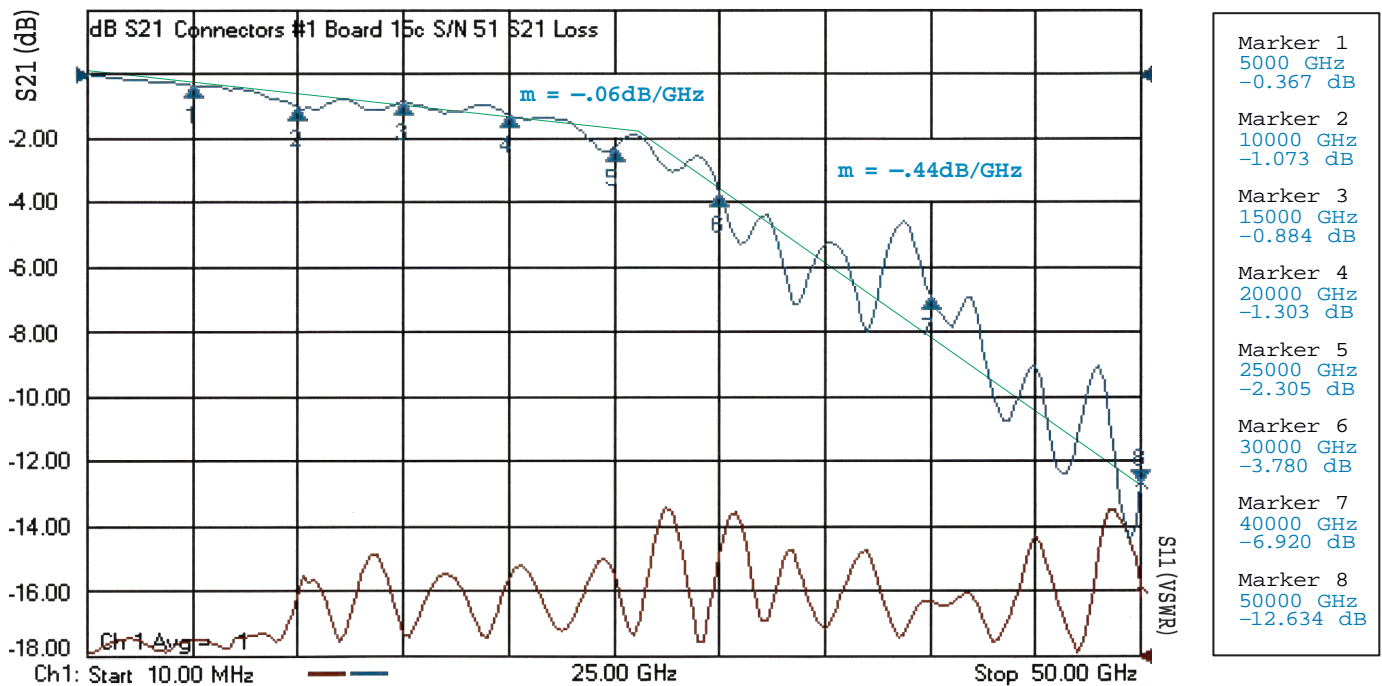

Actual test data for 30 mil microstrip board 15c (Serial Number 51) with markers at 5, 10, 15, 20, 25, 30, 40 and 50 GHz.

Loss (2.5" Straight Microstrip Test Board 20c – S/N 54)

Again this data shows how microstrip straight to the edge of the board on 30 mil R04350 has 2 distinct slopes depending on frequency. The low frequency loss is dominated by board loss and the high frequency loss is dominated by radiated loss. Note that even though the board is longer, the total loss is comparable at 50 GHz. This shows that the radiated loss is most likely occurring mostly at the launch.



Straight Microstrip			
	Board 20c	Loss/Inch	Loss/Launch
5 GHz	0.5	0.1	0.1
10 GHz	0.9	0.2	0.2
15 GHz	1.4	0.3	0.3
20 GHz	1.8	0.4	0.4
25 GHz	2.3	0.5	0.5
30 GHz	4.3	0.7	1.3
35 GHz	6.8	0.9	2.3
40 GHz	9.3	1.1	3.3
45 GHz	11.8	1.3	4.3
50 GHz	14.3	1.5	5.3

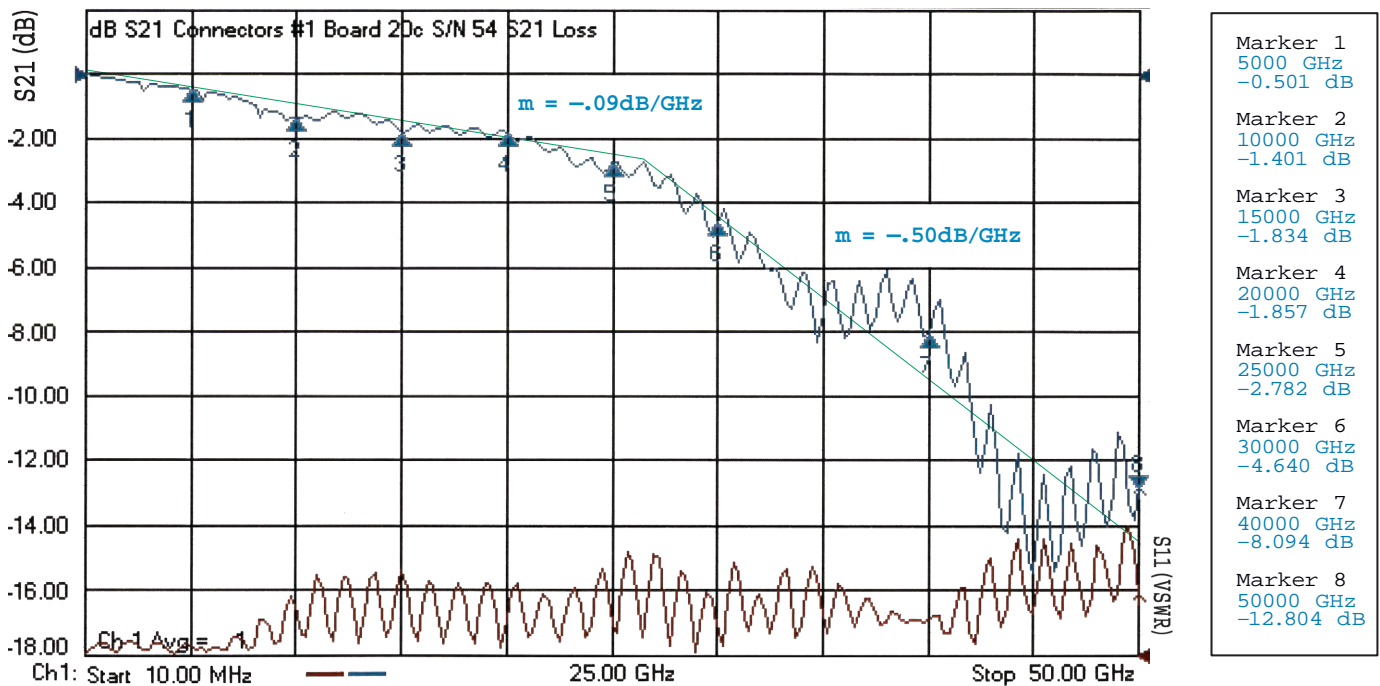

Actual test data for 30 mil microstrip board 20c (Serial Number 54) with markers at 5, 10, 15, 20, 25, 30, 40 and 50 GHz.

Loss (1" Top Ground Microstrip Test Board 14c – S/N 52)

This data shows how microstrip with a top ground launch on 30 mil R04350 has 2 distinct slopes depending on frequency. The low frequency loss is dominated by board loss and the high frequency loss is dominated by radiated loss. To calculate board loss the low frequency region should be used.

← 1" →

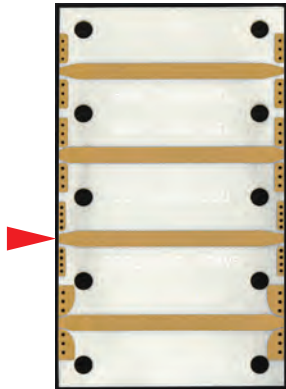

Top Ground Microwave			
	Board 14c	Loss/Inch	Loss/Launch
5 GHz	0.3	0.1	0.1
10 GHz	0.6	0.2	0.2
15 GHz	0.9	0.3	0.3
20 GHz	1.2	0.4	0.4
25 GHz	1.5	0.5	0.5
30 GHz	1.8	0.6	0.6
35 GHz	2.7	0.8	0.9
40 GHz	3.6	1.0	1.3
45 GHz	4.5	1.1	1.7
50 GHz	5.4	1.3	2.0

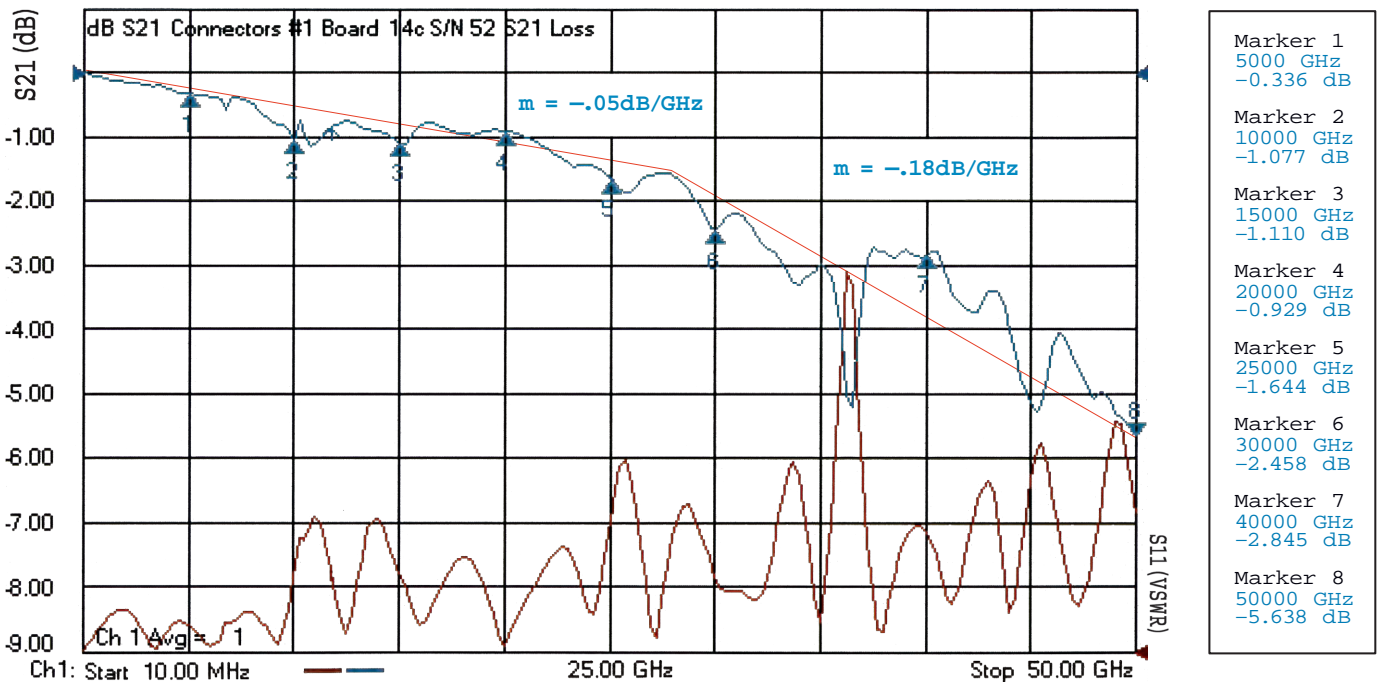

Actual test data for 30 mil microstrip board 14c (Serial Number 52) with markers at 5, 10, 15, 20, 25, 30, 40 and 50 GHz.

Loss (2.5" Top Ground Microstrip Test Board 19c – S/N 53)

Again this data shows how microstrip with a top ground launch on 30 mil R04350 has 2 distinct slopes depending on frequency. The low frequency loss is dominated by board loss and the high frequency loss is dominated by radiated loss. Note that even though the board is longer, the total loss is comparable at 50 GHz. This shows that the radiated loss is most likely occurring mostly at the launch.

← 2.5" →



Top Ground Microwave			
	Board 19c	Loss/Inch	Loss/Launch
5 GHz	0.5	0.1	0.1
10 GHz	0.9	0.2	0.2
15 GHz	1.4	0.3	0.3
20 GHz	1.8	0.4	0.4
25 GHz	2.3	0.5	0.5
30 GHz	2.7	0.6	0.6
35 GHz	3.9	0.8	0.9
40 GHz	5.0	1.0	1.3
45 GHz	6.2	1.1	1.7
50 GHz	7.3	1.3	2.0

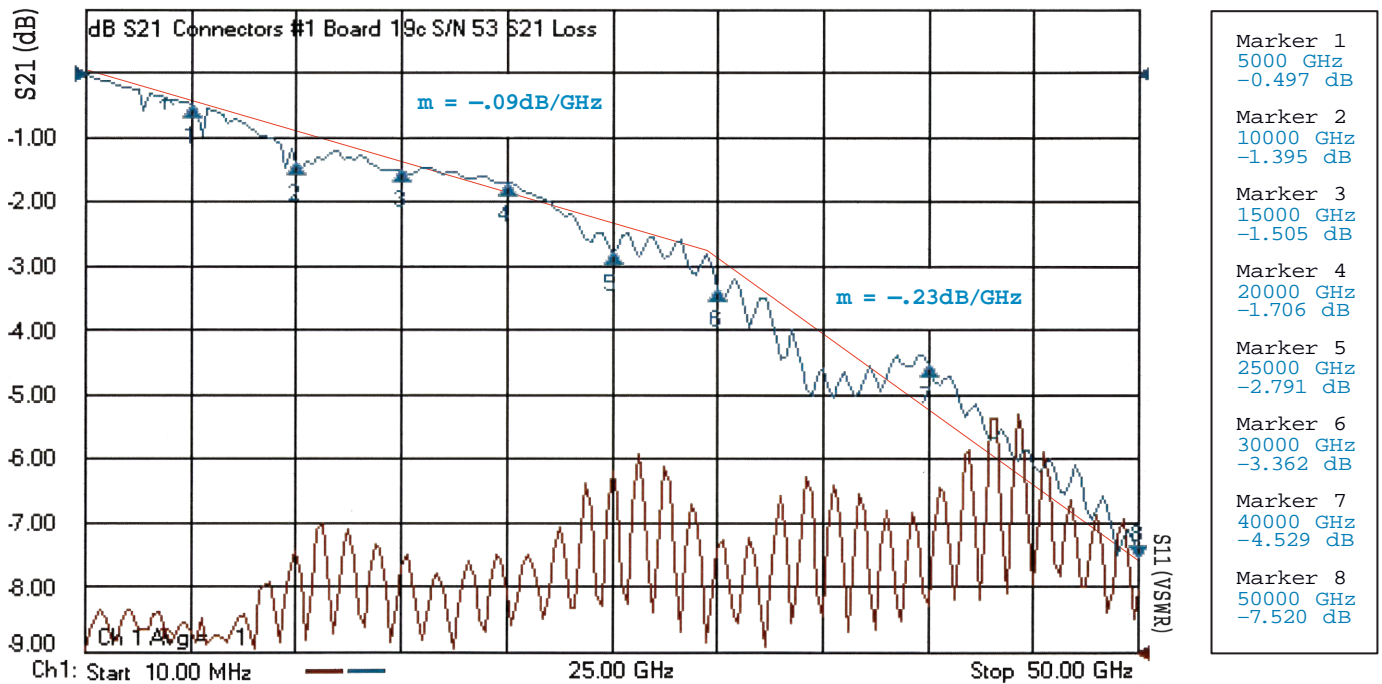

Actual test data for 30 mil microstrip board 19c (Serial Number 53) with markers at 5, 10, 15, 20, 25, 30, 40 and 50 GHz.

Loss (1" GCPWG Test Board 2 – S/N 10)

This data shows how grounded coplanar waveguide (GCPWG) on 30 mil RO4350 has a linear loss curve over frequency. There is not the radiated loss that the microstrip boards have, but the board loss is significantly higher.

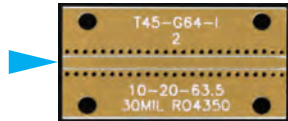

GCPWG			
	Board 2	Loss/Inch	Loss/Launch
5 GHz	0.3	0.2	0.03
10 GHz	0.6	0.5	0.07
15 GHz	0.9	0.7	0.10
20 GHz	1.2	0.9	0.13
25 GHz	1.5	1.2	0.17
30 GHz	1.8	1.4	0.20
35 GHz	2.1	1.6	0.23
40 GHz	2.4	1.9	0.27
45 GHz	2.7	2.1	0.30
50 GHz	3.0	2.3	0.33

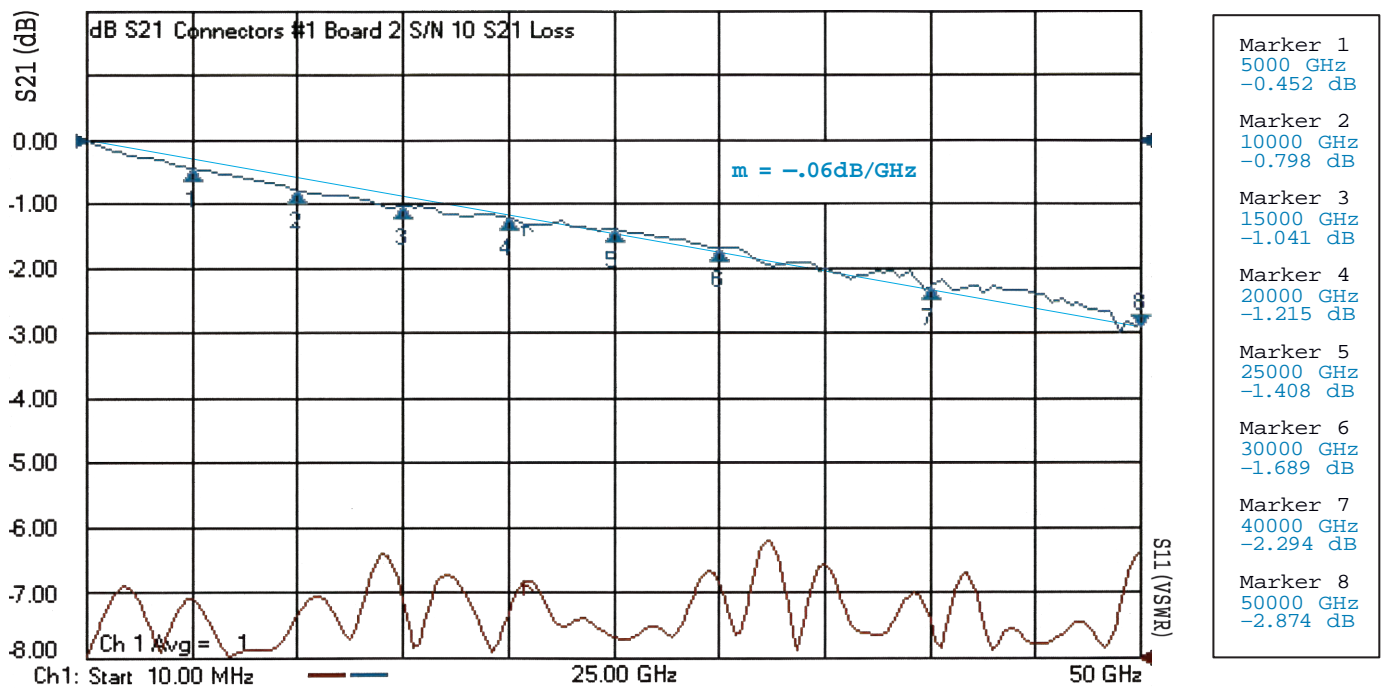

Actual test data for 30 mil coplanar board 2 (Serial Number 10) with markers at 5, 10, 15, 20, 25, 30, 40 and 50 GHz.

Loss (2.5" GCPWG Test Board 12b – S/N 45)

Again this data shows how GCPWG on 30 mil R04350 has a linear loss curve over frequency. But the higher board loss can make longer GCPWG boards have significantly higher loss at frequencies where microstrip board loss is not swamped by radiated losses.

← 2.5" →

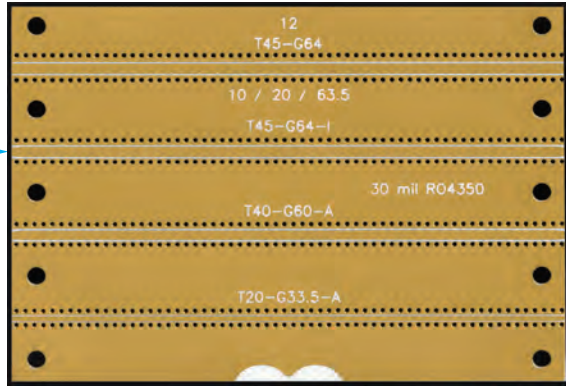

GCPWG			
	Board 12b	Loss/Inch	Loss/Launch
5 GHz	0.7	0.2	0.03
10 GHz	1.3	0.5	0.07
15 GHz	2.0	0.7	0.10
20 GHz	2.6	0.9	0.13
25 GHz	3.3	1.2	0.17
30 GHz	3.9	1.4	0.20
35 GHz	4.6	1.6	0.23
40 GHz	5.2	1.9	0.27
45 GHz	5.9	2.1	0.30
50 GHz	6.5	2.3	0.33

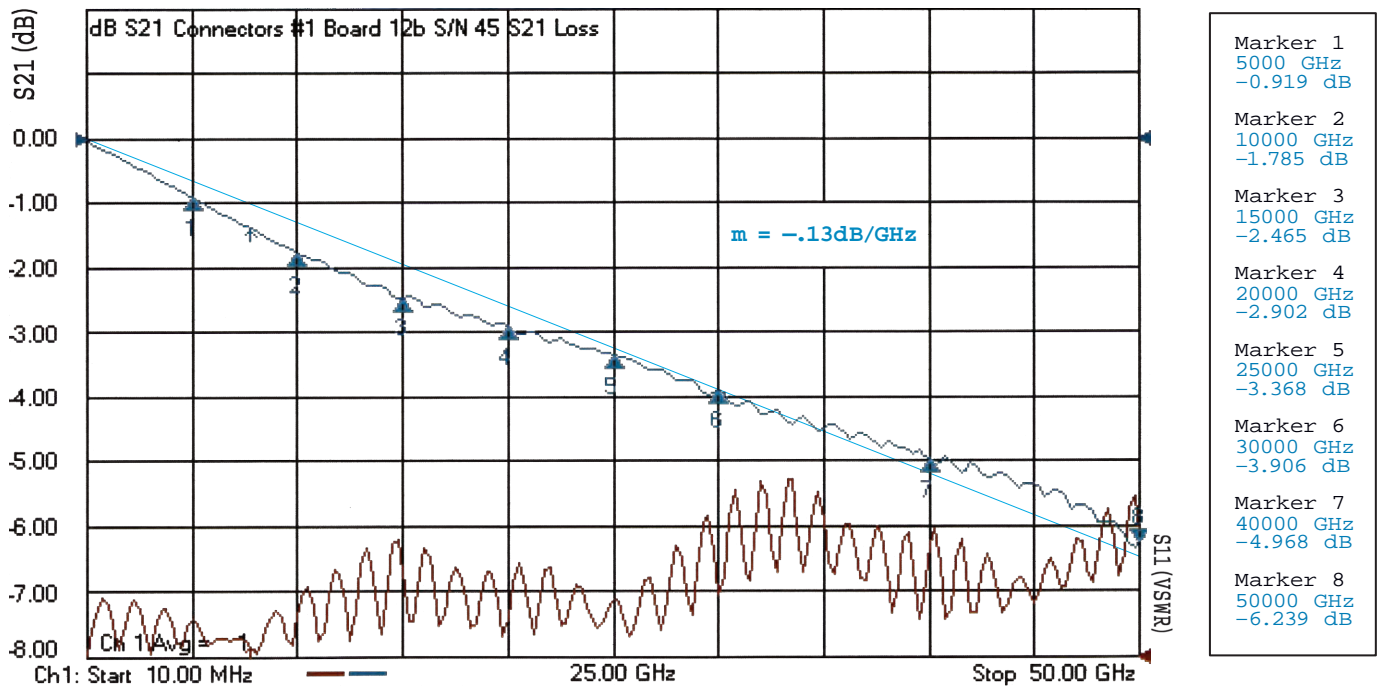

Actual test data for 30 mil coplanar board 12b (Serial Number 45) with markers at 5, 10, 15, 20, 25, 30, 40 and 50 GHz.

Loss

1" GCPWG 1" Top Ground Microstrip 1" Straight Microstrip

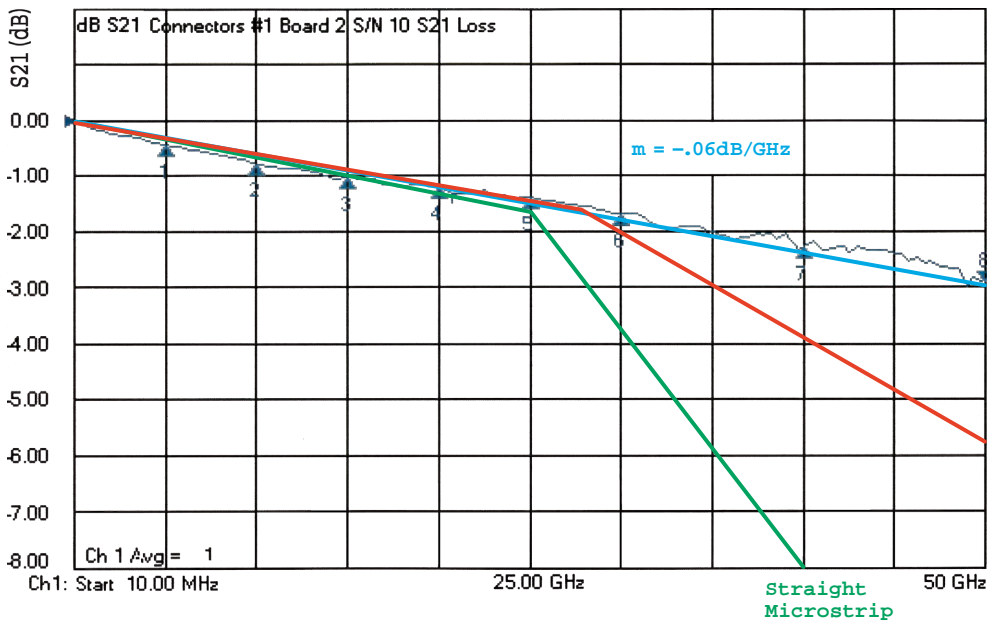

Comparison of actual test data from 1" GCPWG, 1" Top Ground Microstrip, and 1" Straight Microstrip Test Boards.

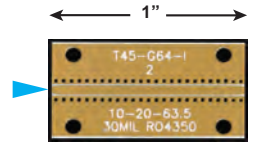

GCPWG test board 2, S/N 10



Top ground microstrip test board 14c, S/N 52



Straight microstrip test board 15c, S/N 51

Loss

2.5" GCPWG 2.5" Top Ground Microstrip 2.5" Straight Microstrip

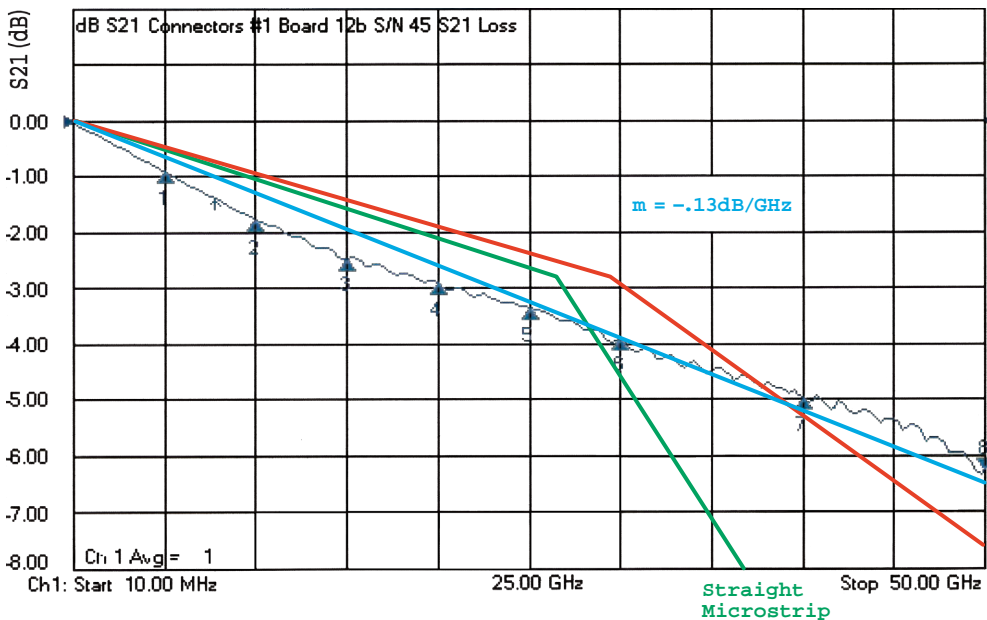

Comparison of actual test data from 2½" GCPWG, 2½" Top Ground Microstrip, and 2½" Straight Microstrip Test Boards.

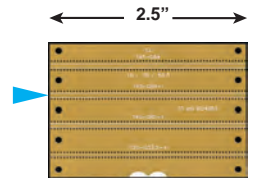

GCPWG test board 20c, S/N 45



Top ground microstrip test board 19c, S/N 53



Straight microstrip test board 20c, S/N 54

Loss (Summary)

The differences between the loss curves of microstrip run straight to the edge of the board, microstrip with a top ground launch, and GCPWG have been shown in this study. The microstrip run straight to the edge had the most radiated loss, but at lower frequencies the loss was reasonable. The microstrip with a top ground launch had less radiated loss than the straight microstrip and much more radiated loss than GCPWG. The GCPWG had much less radiated loss, but much more line loss.

	Straight Microstrip		Top Ground Microstrip		GCPWG	
	Loss/Inch	Loss/Launch	Loss/Inch	Loss/Launch	Loss/Inch	Loss/Launch
5 GHz	0.1	0.1	0.1	0.1	0.2	0.03
10 GHz	0.2	0.2	0.2	0.2	0.5	0.07
15 GHz	0.3	0.3	0.3	0.3	0.7	0.10
20 GHz	0.4	0.4	0.4	0.4	0.9	0.13
25 GHz	0.5	0.5	0.5	0.5	1.2	0.17
30 GHz	0.7	1.3	0.6	0.6	1.4	0.20
35 GHz	0.9	2.3	0.8	0.9	1.6	0.23
40 GHz	1.1	3.3	1.0	1.3	1.9	0.27
45 GHz	1.3	4.3	1.1	1.7	2.1	0.30
50 GHz	1.5	5.3	1.3	2.0	2.3	0.33

Actual test data comparison for the Straight Microstrip board, the Top Grounded Microstrip and the (GCPWG) Grounded Coplanar Waveguide at 5, 10, 15, 20, 25, 30, 40 and 50 GHz.

Conclusion

For 30 mil thick R04350 substrates used for up to 50 GHz, properly designed grounded coplanar waveguide (GCPWG) has been shown to have some advantages. But for loss there are applications where microstrip would be the better choice.

This means the application would determine which structure is the best to use. If loss is the only concern for longer lines microstrip will be the better choice. For bandwidth, isolation, and if lines are very short then GCPWG would be the better choice.

Hopefully this study has been helpful to board designers working at microwave frequencies to have a better understanding of launch and transmission line structures.

Appendix A: Test Boards 2-4 (Variables and Results)

Test Board 2

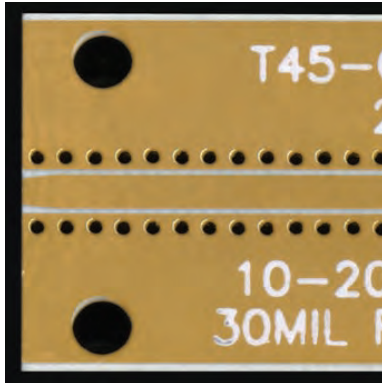

Enlarged view of coplanar test board shown to the right.

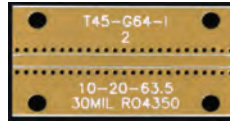

Board 2

Serial Number 10
Trace = 45
Ground = 64

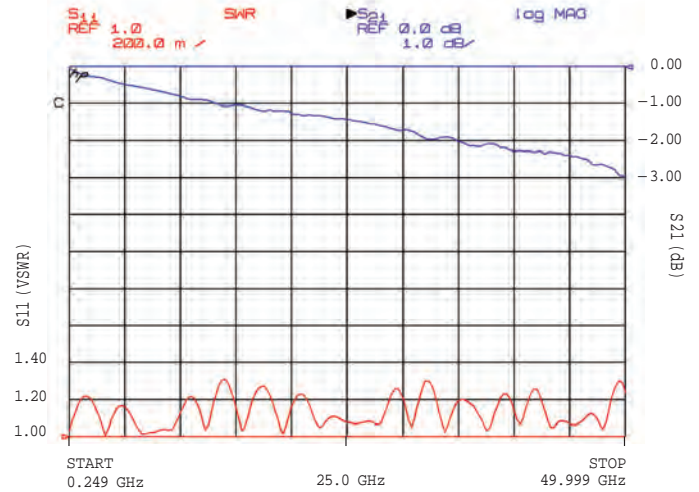

Actual test results from Board 2 (Serial Number 10).

Test Board 3

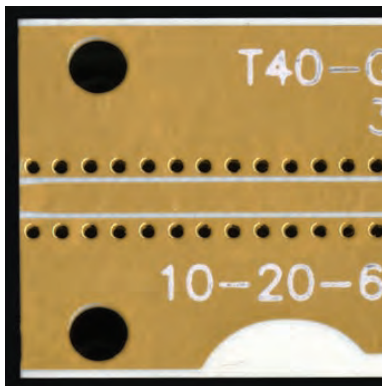

Enlarged view of coplanar test board shown to the right.

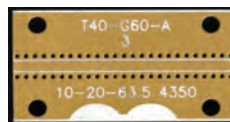

Board 3

Serial Number 24
Trace = 40
Ground = 60

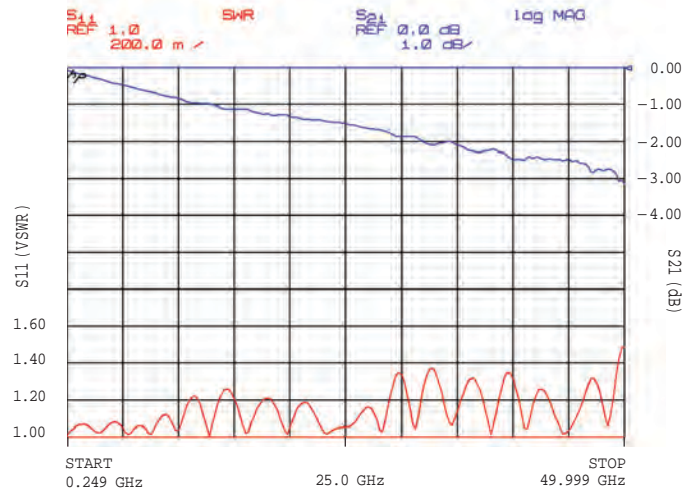

Actual test results from Board 3 (Serial Number 24).

Test Board 4

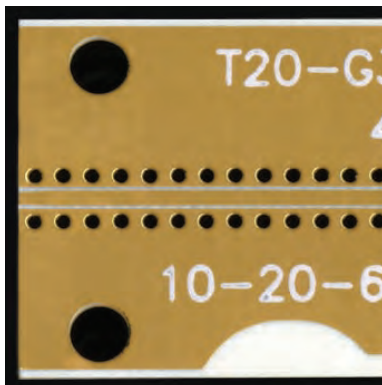

Enlarged view of coplanar test board shown to the right.

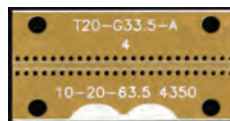

Board 4

Serial Number 28
Trace = 20
Ground = 33.5

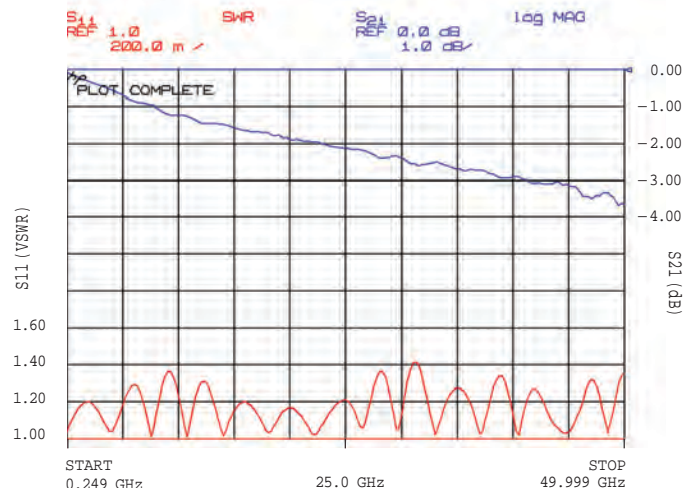

Actual test results from Board 4 (Serial Number 28).

Appendix A: Test Boards 5a-5c (Variables and Results)

Test Board 5a

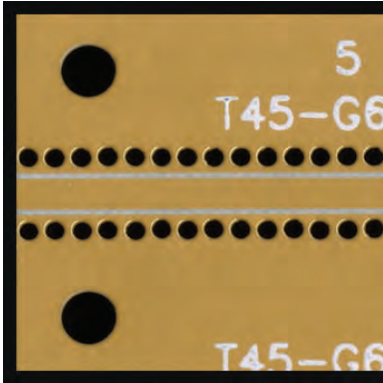

Enlarged view of coplanar test board shown to the right.

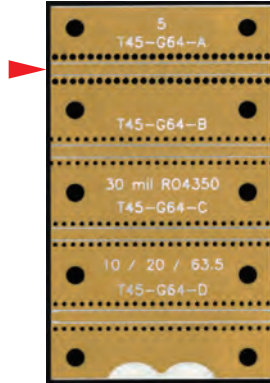

Board 5a (see green arrow)
Serial Number 32
Trace = 45
Ground = 64

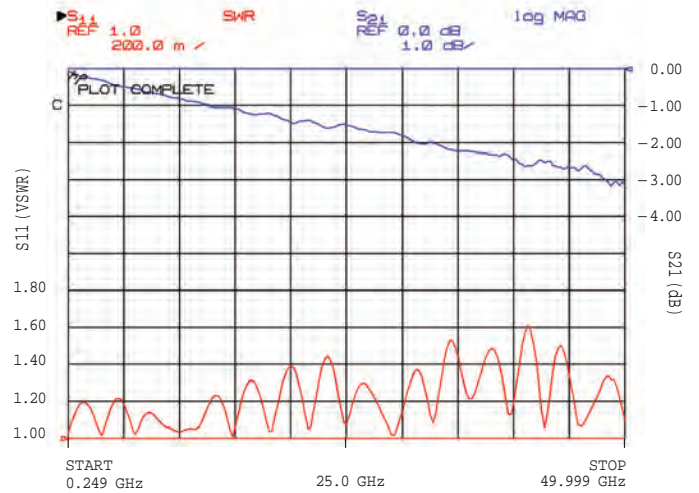

Actual test results from Board 5a (Serial Number 32).

Test Board 5b

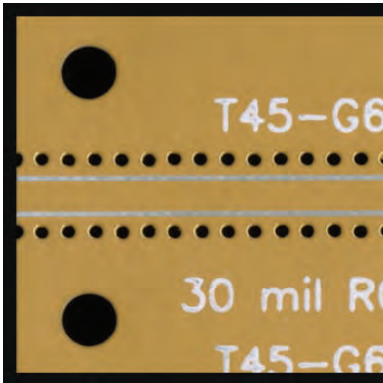

Enlarged view of coplanar test board shown to the right.

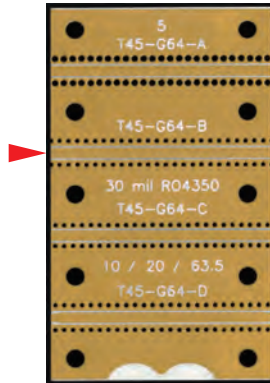

Board 5b (see green arrow)
Serial Number 32
Trace = 45
Ground = 64

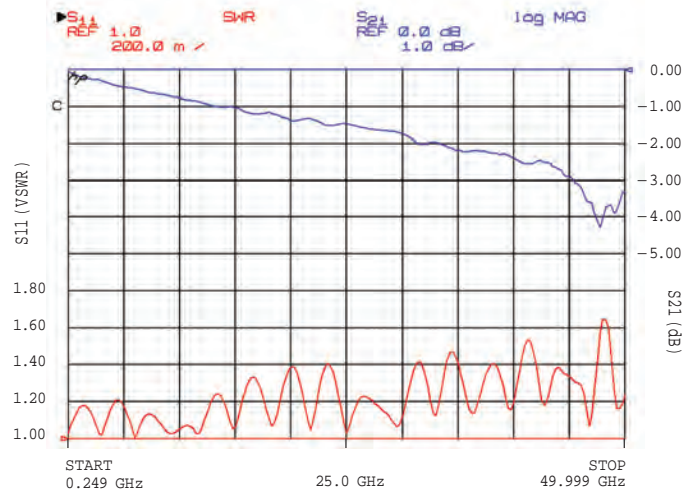

Actual test results from Board 5b (Serial Number 32).

Test Board 5c

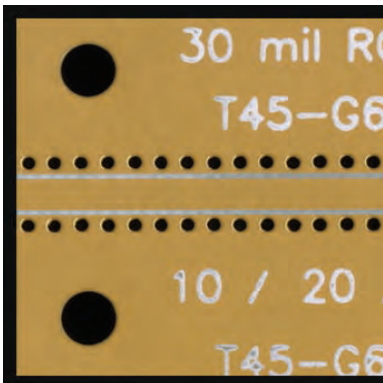

Enlarged view of coplanar test board shown to the right.

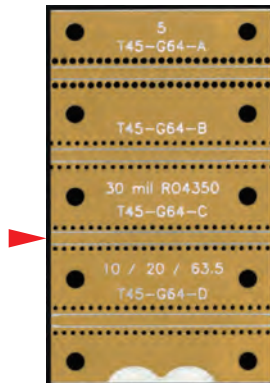

Board 5c (see green arrow)
Serial Number 32
Trace = 45
Ground = 64

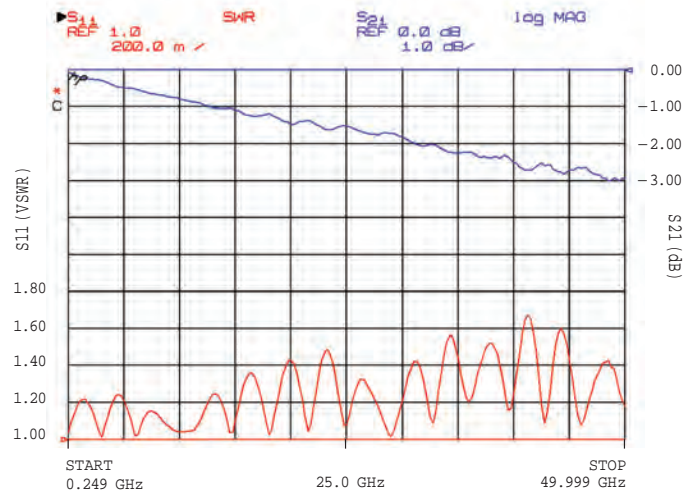

Actual test results from Board 5c (Serial Number 32).

Appendix A: Test Boards 5d-6b (Variables and Results)

Test Board 5d

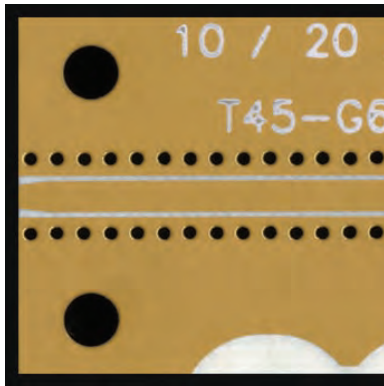

Enlarged view of coplanar test board shown to the right.

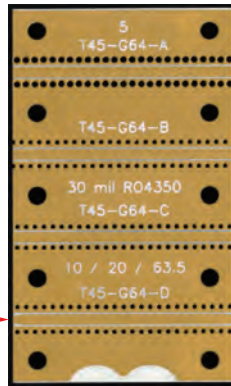

Board 5d (see green arrow)
Serial Number 32
Trace = 45
Ground = 64

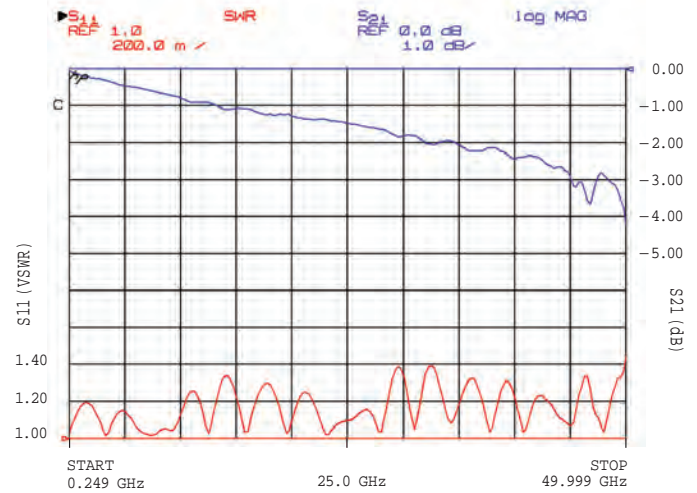

Actual test results from Board 5d (Serial Number 32).

Test Board 6a

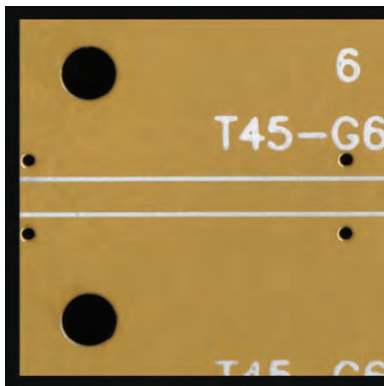

Enlarged view of coplanar test board shown to the right.

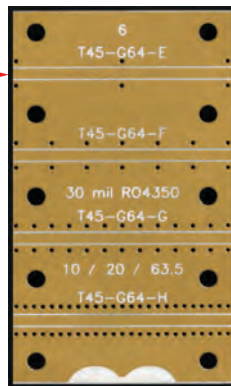

Board 6a (see green arrow)
Serial Number 35
Trace = 45
Ground = 64

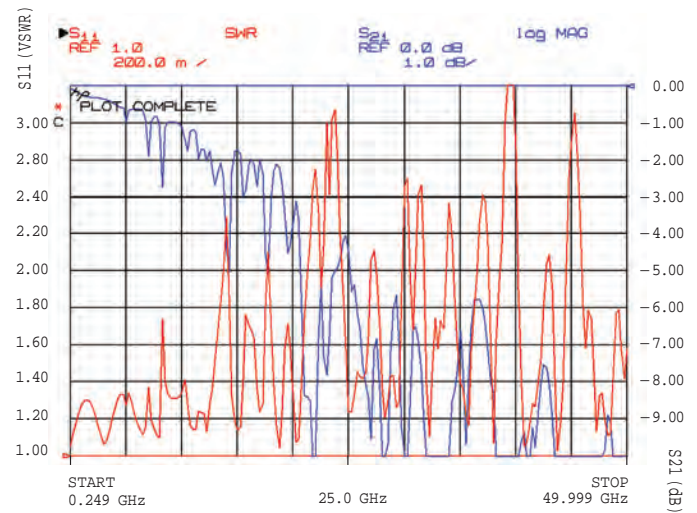

Actual test results from Board 6a (Serial Number 35).

Test Board 6b

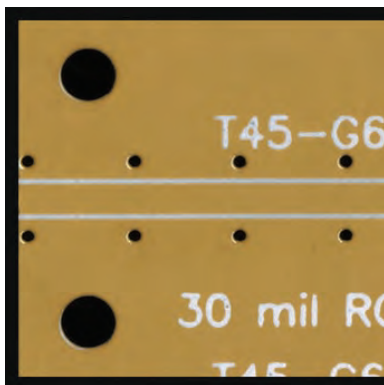

Enlarged view of coplanar test board shown to the right.

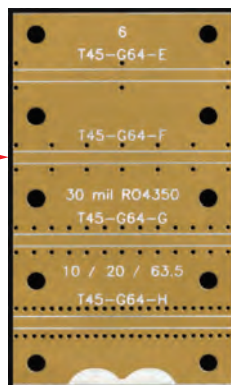

Board 6b (see green arrow)
Serial Number 35
Trace = 45
Ground = 64

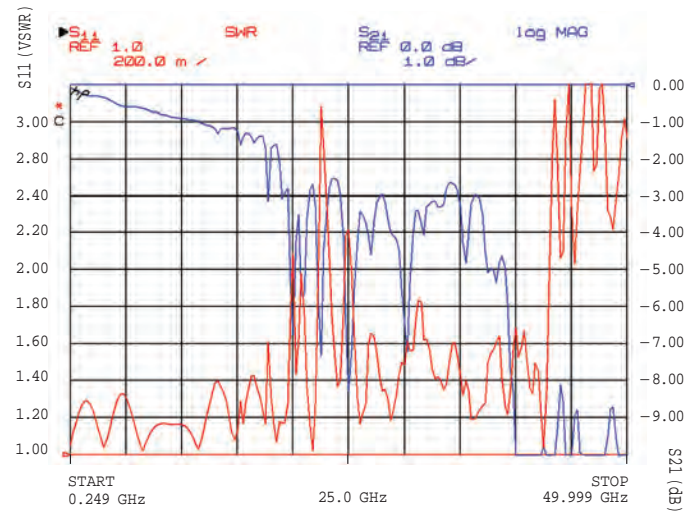

Actual test results from Board 6b (Serial Number 35).

Appendix A: Test Boards 6c-7a (Variables and Results)

Test Board 6c

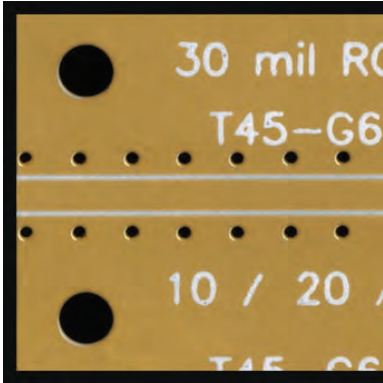

Enlarged view of coplanar test board shown to the right.

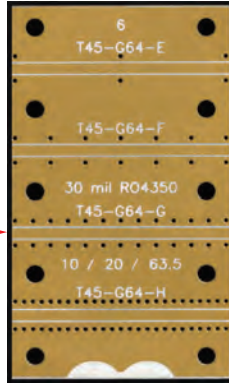

Board 6c (see green arrow)
Serial Number 35
Trace = 45
Ground = 64

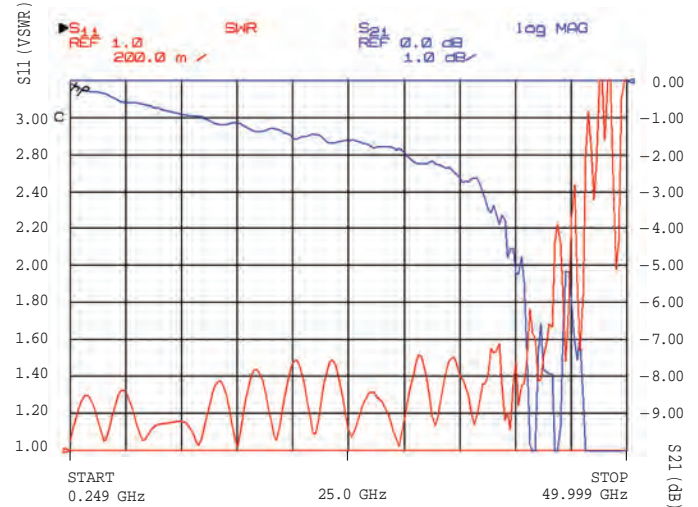

Actual test results from Board 6c (Serial Number 35).

Test Board 6d

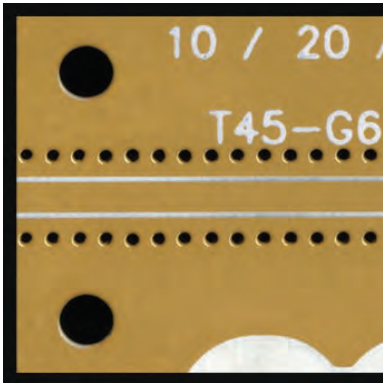

Enlarged view of coplanar test board shown to the right.

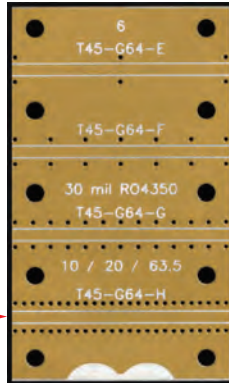

Board 6d (see green arrow)
Serial Number 34
Trace = 45
Ground = 64

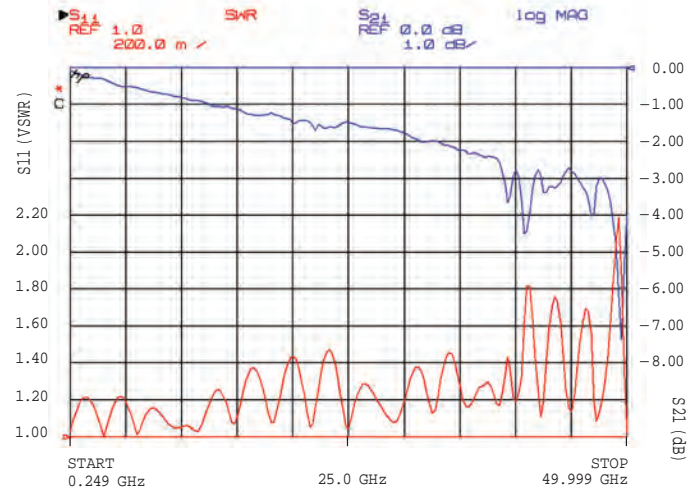

Actual test results from Board 6d (Serial Number 34).

Test Board 7a

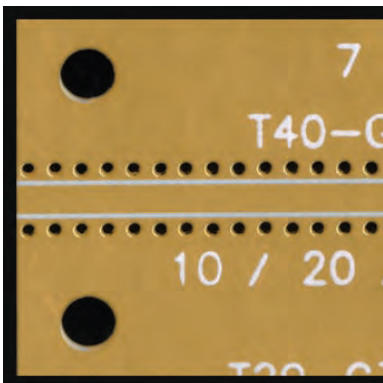

Enlarged view of coplanar test board shown to the right.

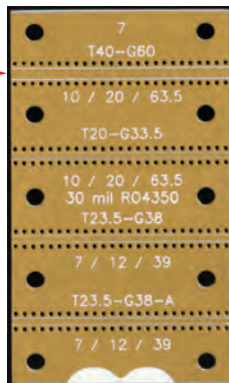

Board 7a (see green arrow)
Serial Number 36
Trace = 40
Ground = 50

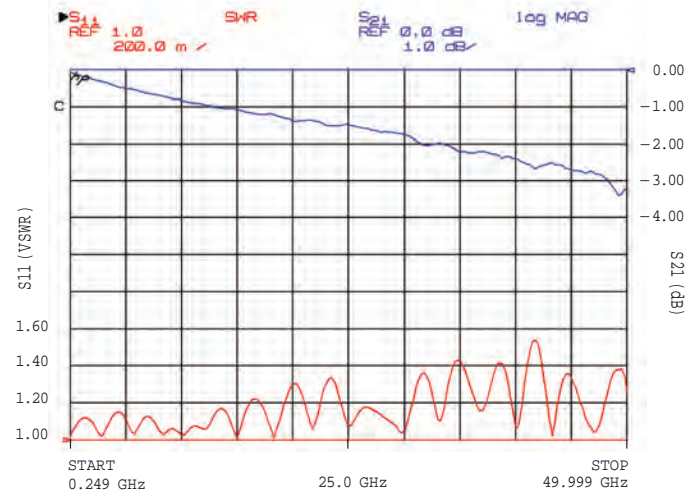

Actual test results from Board 7a (Serial Number 36).

Notes



Notes





The Performance Leader in Microwave Connectors

Southwest Microwave, Inc. is the leader in hi-performance interconnect products for millimeter wave and microwave applications. Providing the best value through performance as well as:

- Low VSWR
- Low Insertion Loss
- Low RF Leakage
- High Temperature
- Higher Power Handling
- Excellent Repeatability
- Rugged & Durable

Visit us on-line @: www.southwestmicrowave.com

Southwest Microwave, Inc.

9055 S. McKemy St., Tempe, AZ 85284-2946 USA

Phone: 480.783.0201 ■ Fax: 480.783.0360