

The Performance Leader in Microwave Connectors



***The Design & Test of Broadband Launches
up to 50 GHz on Thin & Thick Substrates***

Thin Substrate: 8 mil Rogers R04003 Substrate

Thick Substrate: 30 mil Rogers R04350 Substrate

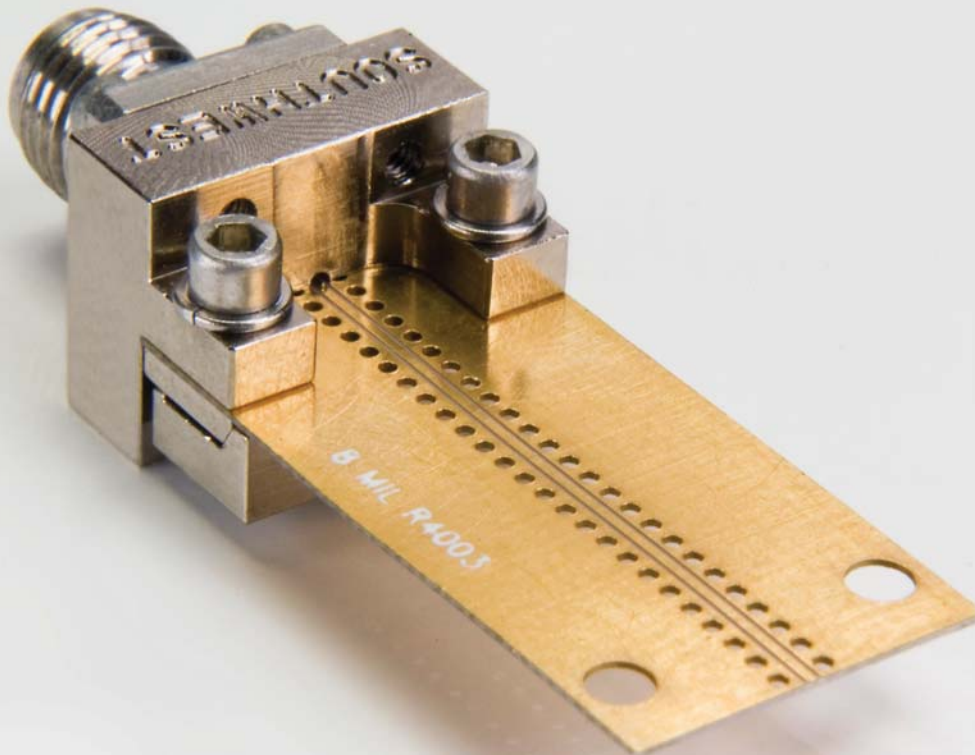

Southwest Microwave, Inc.

www.southwestmicrowave.com ■ *Tempe, Arizona USA*

Southwest Microwave, Inc.

***The Design and Test of Broadband Launches
up to 50 GHz on Thin and Thick Substrates***

*Thin Substrate: 8 mil Rogers R04003 Substrate
Thick Substrate: 30 mil Rogers R04350 Substrate*

Table of Contents

Purpose	2
<i>Scope of the Evaluation</i>	2
Southwest Microwave End Launch Connectors	3
<i>Connector Model</i>	3
<i>End Launch Connector Features</i>	4
<i>Relative Sizes of the End Launch Connectors</i>	5
Test Equipment and Techniques	6
<i>Analyzer Workstation (HP 8510C)</i>	6
<i>SMI Format of S-parameter Data</i>	6
Comparison of Straight Microstrip, Top Ground Microstrip and GCPWG	7
An Example of Launch Optimization	8
<i>Original Test Board Design</i>	8
<i>Time Domain (TDR) Test data</i>	8
<i>3-D Simulation</i>	9
<i>Taper (Version 1)</i>	10
<i>Optimized Taper (Version 2)</i>	11
Optimized Boards – Final Layouts	12
<i>Straight Microstrip</i>	12
<i>Top Ground Microstrip</i>	12
<i>GCPWG</i>	13
Loss Data	14
<i>Scope</i>	14
<i>Loss (Straight Microstrip)</i>	14
<i>Loss (Top Ground Microstrip)</i>	16
<i>Advantages of Top Ground Microstrip on 30 mil Boards</i>	18
<i>Loss (GCPWG)</i>	20
Conclusion	22
Appendix <i>Loss (Summary)</i>	24

Purpose

Customers often contact Southwest Microwave wanting to know why there are four different pin sizes on the end launch connector. The purpose of the paper is to explain that they are needed to optimally match the connector to different substrate thicknesses. As a result of our study of 50 GHz transmission lines and launches, SMI has determined that the practical range of substrate thicknesses of Rogers 4000 series material that are optimizable are 8 mil to 30 mil. Substrates that are thinner than 8 mil have line widths that are too small to optimize the launch with a taper for even the smallest connector pin. For substrates that are thicker than 30 mil there can be line structures created that achieve a good match and bandwidth to 50 GHz, but the loss of these lines start to significantly increase at higher frequencies.

This paper will explore the behavior of thick and thin substrate transmission lines and launches. These are not necessarily the ideal board thicknesses to use.

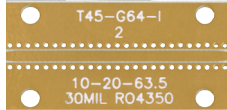
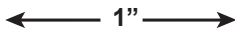

30 MIL GCPWG Board



8 MIL GCPWG Board

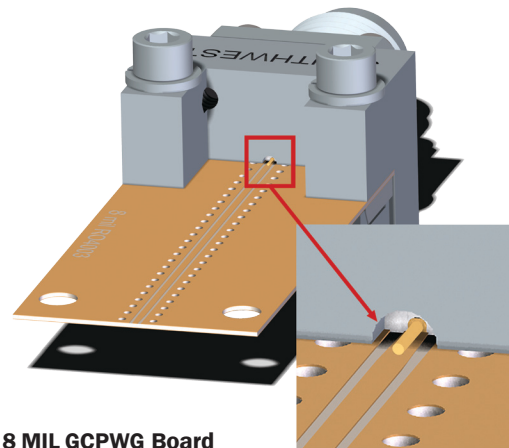

8 MIL GCPWG Board

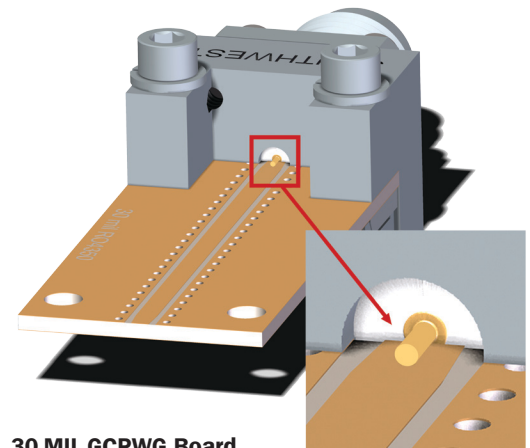

30 MIL GCPWG Board

Scope of the Evaluation

This evaluation explores three different transmission line structures on 8 mil RO4003 and 30 mil RO4350 boards. The launch geometries on the boards are all optimized and the modeling technique used will be explored in an example. The two line types evaluated were grounded coplanar waveguide (GCPWG) and microstrip. For microstrip there were two launch types evaluated; microstrip lines running straight to the edge of the board and top ground (GCPWG) launches to microstrip lines. There are two different models of 2.4mm end launch connectors used; one with a 5 mil launch pin that transitions to a 9 mil pin in the connector, and one with a 10 mil launch pin that transitions to a 20 mil pin in the connector.

The mechanics of the layouts were done by a consultant (Petra Microwave) and the boards were fabricated by Accurate Circuit Engineering in Southern California.

Southwest Microwave End Launch Connectors

Connector Models

The connectors used are SMI end launch connector assemblies, model numbers 1492-02A-5 and 1492-04A-5. These connectors were designed for single-layer boards and multi-layer boards where the top layer is the microwave layer.

The 1492-02A-5 has a 2.4 mm female connector, a transition block with a 10 mil diameter circuit launch pin, and a 63.5 mil diameter coaxial ground with a center conductor of 20 mil. The 1492-04A-5 has a 2.4 mm female connector, a transition block with a 5 mil diameter circuit launch pin, and a 29 mil diameter coaxial ground with a center conductor of 9 mil.

Because they can be used on multi-layer boards there is a 20 mil overhang of the ground over the board to catch the top ground of the board.

No soldering is needed due to a slight interference fit between the circuit pin and the board to ensure good contact.

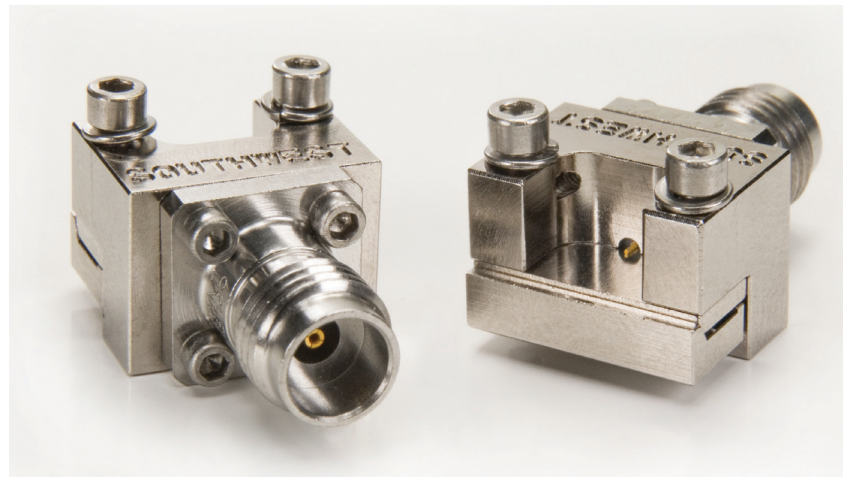

Front and back views of SMI 2.40 mm (50 GHz) End Launch Assemblies.

LAUNCH GEOMETRY		END LAUNCH CONNECTOR MODEL NUMBERS						TRANSITION DIAMETERS			REFERENCE		
		SMA CONNECTOR (27 GHz)		2.92mm CONNECTOR (40 GHz)		2.40mm CONNECTOR (50 GHz)					COPLANAR	MICROSTRIP CIRCUIT GEOMETRY	
		PIN DIAMETER	DIELECTRIC DIAMETER	JACK (FEMALE)	PLUG (MALE)	JACK (FEMALE)	PLUG (MALE)	JACK (FEMALE)	PLUG (MALE)	A	B	C	RECOMMENDED GROUND TO GROUND SPACING
.10	.0635	292-04A-5	293-01A-5	1092-03A-5	1093-01A-5	1492-02A-5	1493-01A-5	.10	.020	.0635	.045" TO .062"	.027"	.010"-.063"
.07	.0480	292-05A-5	293-02A-5	1092-02A-5	1093-02A-5	1492-01A-5	1493-02A-5	.07	.015	.0480	.037" TO .046"	.020"	.007"-.048"
.07	.0390	292-06A-5	293-03A-5	1092-04A-5	1093-03A-5	1492-03A-5	1493-03A-5	.07	.012	.0390	.026" TO .037"	.016"	.007"-.039"
.05	.0290	292-07A-5	293-04A-5	1092-01A-5	1093-04A-5	1492-04A-5	1493-04A-5	.05	.009	.0290	.020" TO .027"	.012"	.007"-.029"

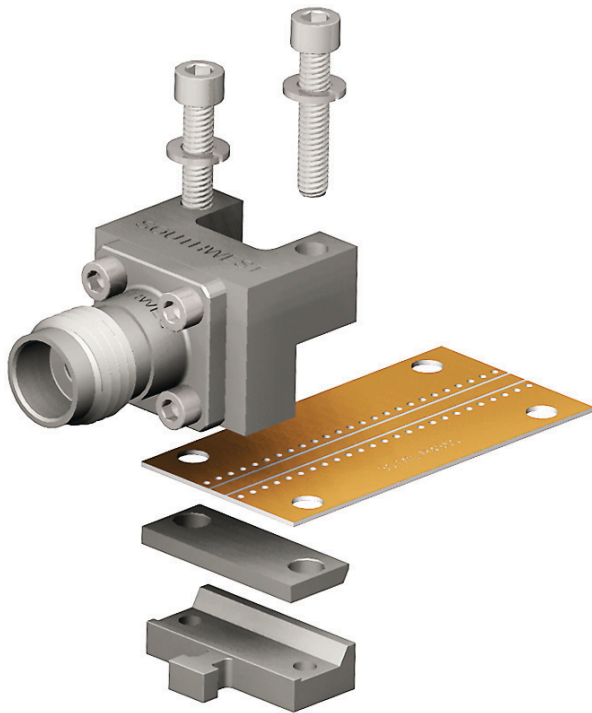

End Launch Connector Features

- ▶ Southwest Microwave end Launch connector assemblies, model number 1492-02A-5 and 1492-04A-5.
- ▶ Used on single-layer boards.
- ▶ Used on multi-layer boards where the top layer is the microwave layer.
- ▶ No soldering is needed.
- ▶ Usable with any board thickness.

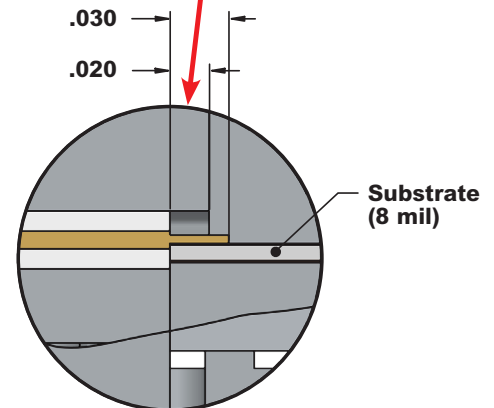
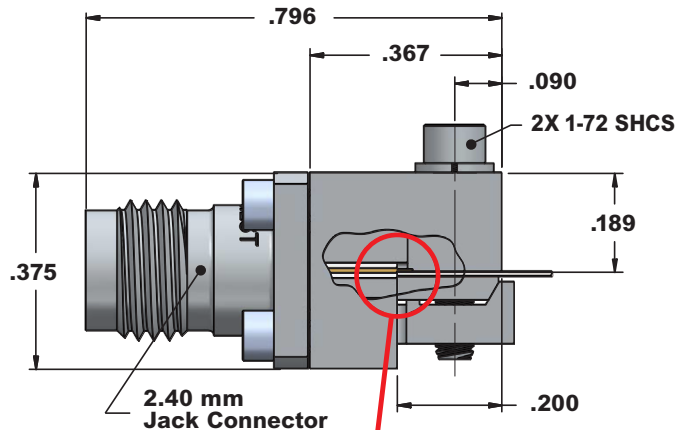
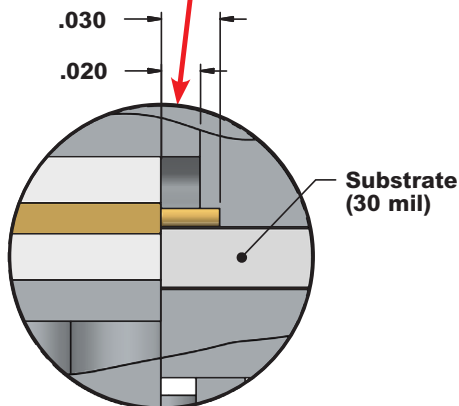
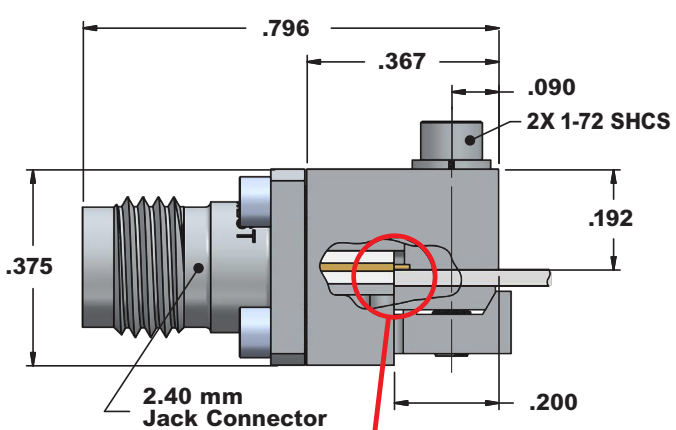

Relative Sizes of the End Launch Connectors

These views show the relative sizes of the pins and the substrates. They illustrate how the larger pin matches with the thicker substrate and the smaller pin matches to the thinner substrate.

The previous page shows side views with dimensions on the relative pin lengths and connector body overhang on to the board. This page shows a rear view with dimensions of the diameters of the connector launch and the substrate thickness.

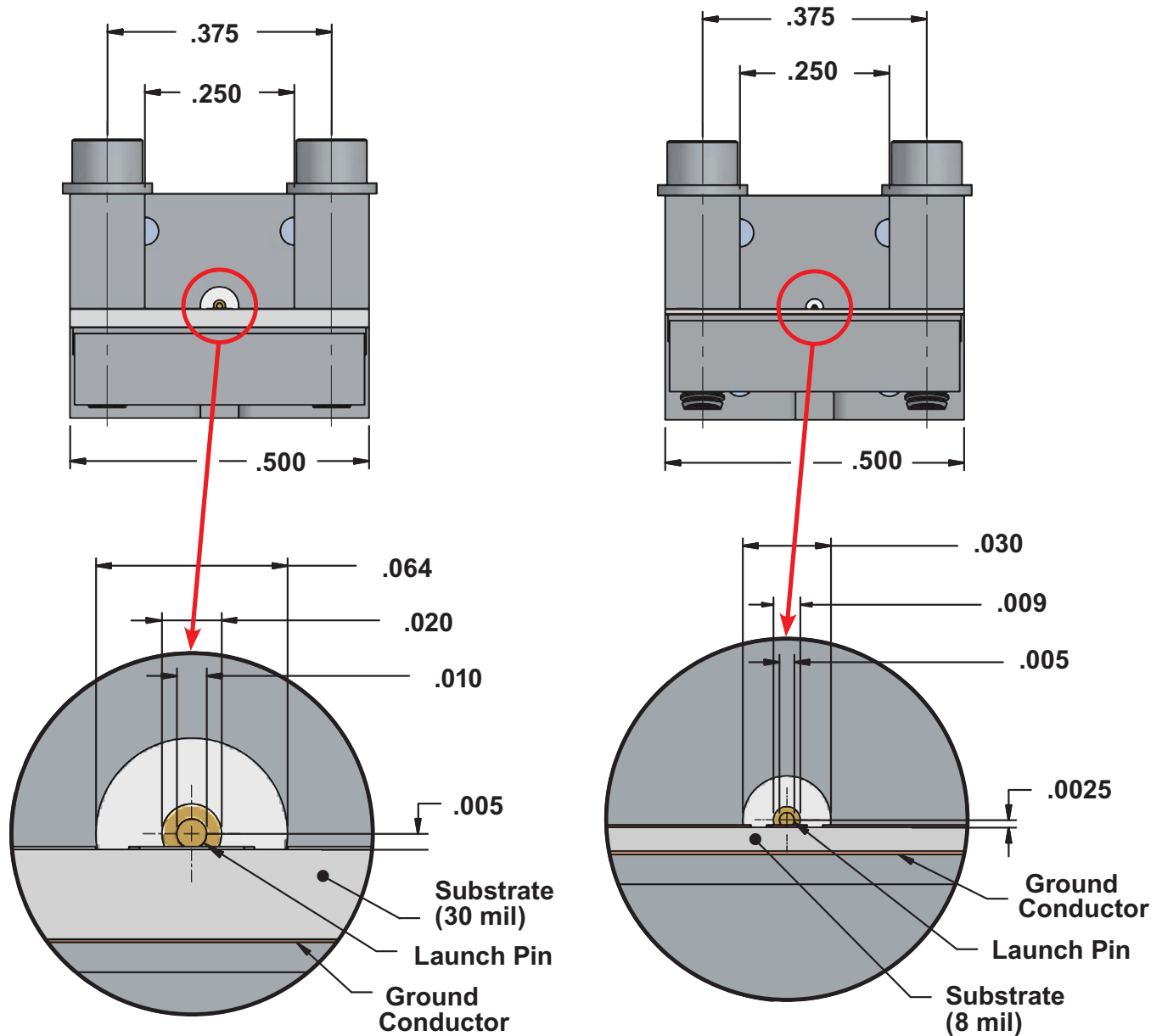



Test Equipment and Techniques

An Agilent 8510C network analyzer was used for all of the published measurements. The test port connectors used were 2.4 mm connectors and the frequency range for all measurements was DC to 50 GHz. Calibration was a full 12-term SOLT calibration with sliding loads. The TDR measurements were set up as low pass step in real units. All of the data was taken from the same calibration. Some internal verification of data was done on an Anritsu 37297 network analyzer.

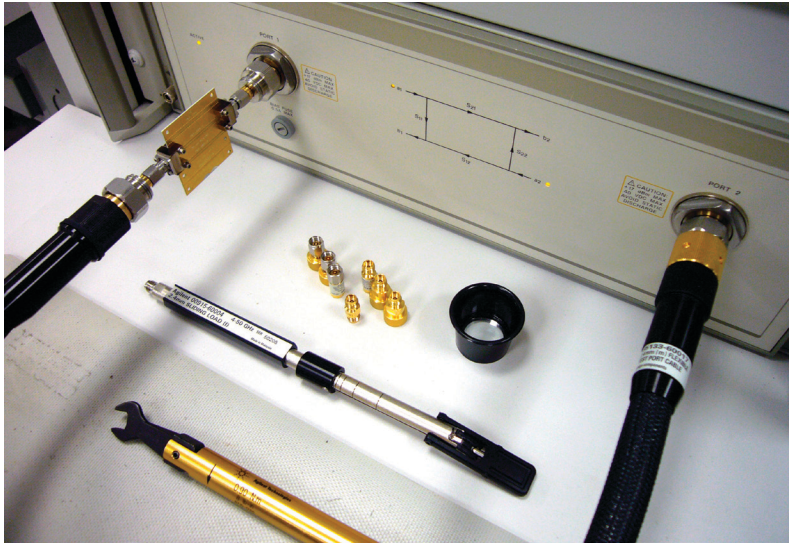

Analyzer Workstation (HP 8510C)

- ▶ 12-term SOLT calibration.
- ▶ Sliding loads were used.
- ▶ Single cable – DUT connected directly to port 1.
- ▶ Non-insertable device handled by swapping phase matched adapters.
- ▶ 201 points.
- ▶ Harmonic sweep for time domain.

SMI Standard Format of S-Parameter Data

S-parameter data:

The format of the data is S11 on the bottom of the graph in VSWR with a scale of 0.2 per division, and S21 on the top of the graph in Log Mag with a scale of 1 dB per division.

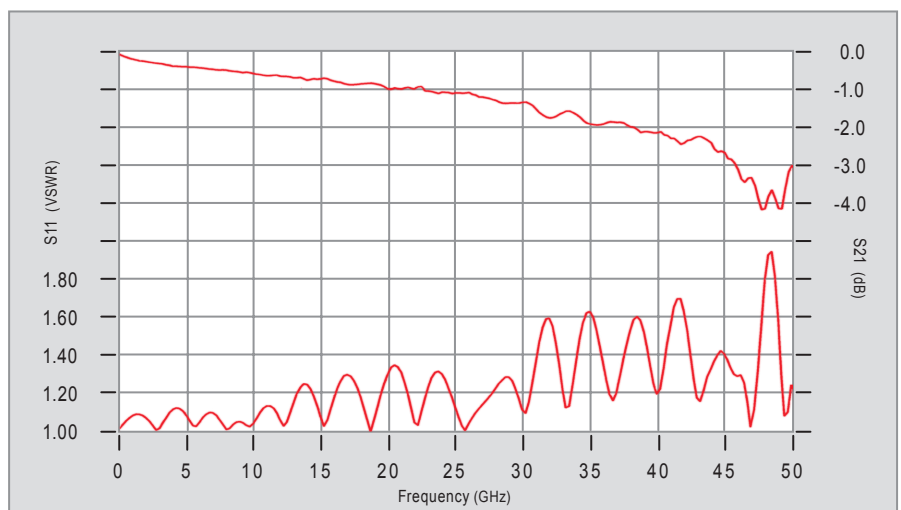

Test data original 30 mil GCPWG test board (Serial Number 0).

Explanation of Launch Types

Straight Microstrip

Straight microstrip refers to a microstrip line straight to the end of the board. The line can be tapered for matching purposes.

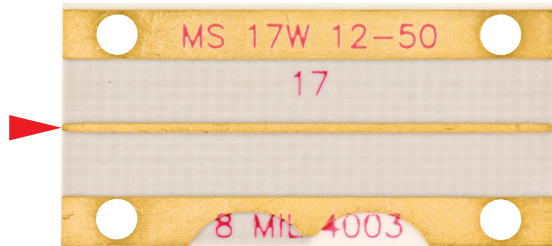

8 MIL R04003 Straight Microstrip

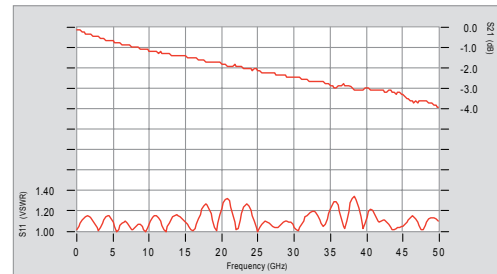

Top Ground Microstrip

Top ground microstrip refers to a microstrip line with a top ground launch structure. The launch geometry is a 50 ohm GCPWG structure. A top ground added to a board can improve microstrip performance and allow for use on multi-layer boards. The line is tapered to match the connector.

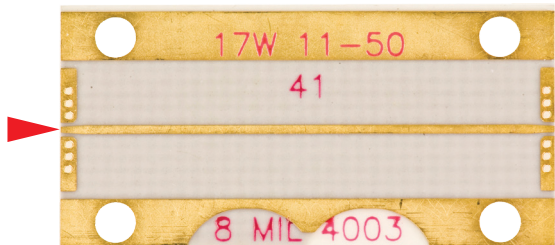

8 MIL R04003 Top Ground Microstrip

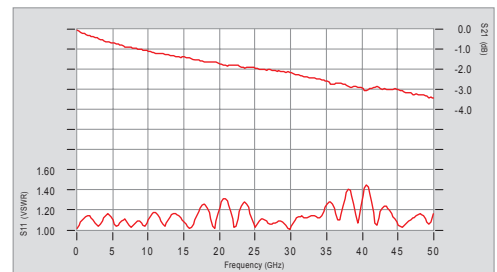

Grounded Coplanar Waveguide (GCPWG)

GCPWG refers to a line and launch structure that is coplanar on top with a ground plane under the signal line. With GCPWG there is the ability to choose line widths and ground spacings that better match to a coax line. A GCPWG can be used on multi-layer boards.

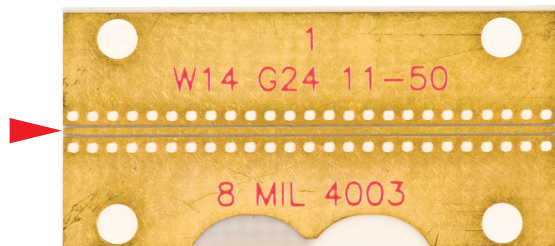

8 MIL R04003 GCPWG

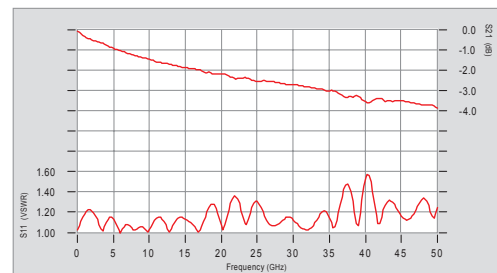

An Example of Launch Optimization

Original Test Board Design

When the end launch connectors were first introduced in 2003, a one-inch long GCPWG test board was developed for testing. One of these original test boards was used to establish the baseline performance of the connectors.

To the right are the results of the original end launch connector test board and a drawing of the board. The VSWR rises slowly through 45 GHz to 1.6:1.

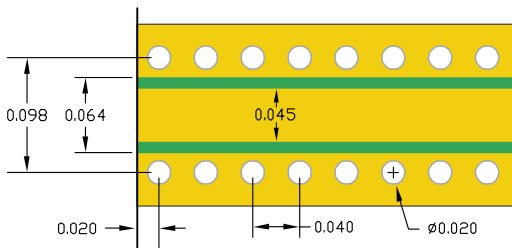

Time Domain (TDR) Test Data

The TDR data to the right is in real units over time. It shows the discontinuity at the launch and the impedance of the board. For more on this type of TDR testing, see the paper "Utilizing Time Domain (TDR) Test Methods" on www.southwestmicrowave.com.

3-D Simulation

Simulation can be used to predict the results of these types of structures then changes can be made and the results of the changes can be viewed without having to fabricate and test actual hardware. Decent correlation of the known performance of this test board was achieved with CST Microwave Studio® (CST MWS) Simulation. CST provided the simulations.

CST MWS Model

The 3-D simulation model is created by looking at only the transition blocks and the test board. The biggest discontinuity in the transmission line is the transition from coax to PCB. The worst transmission line is the PCB. The two coaxial connectors are well matched and have very low loss, so even without them in the simulation, a very good correlation to the actual performance can be achieved.

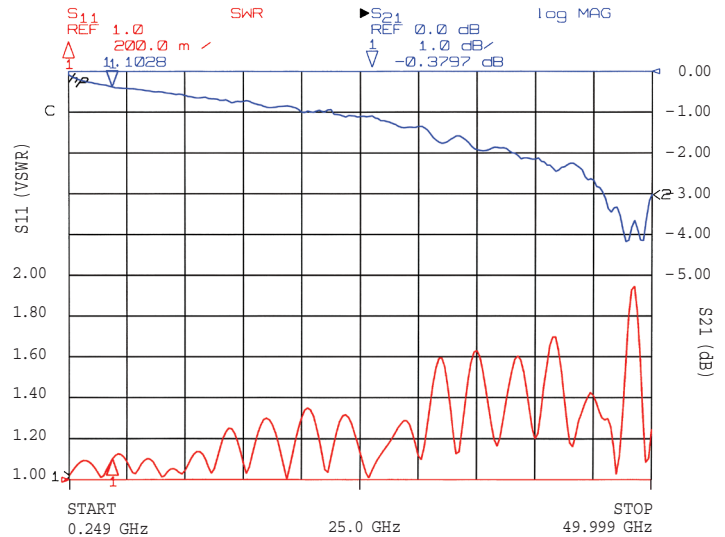

Test data original 30 mil coplanar test board (Serial Number 0).

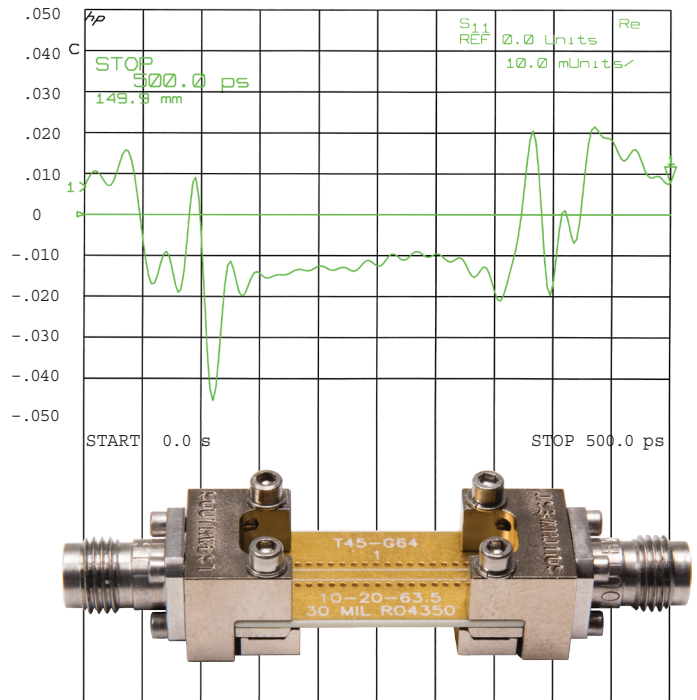

TDR of original coplanar test board (Serial Number 0).

CST MWS Model Without Connectors

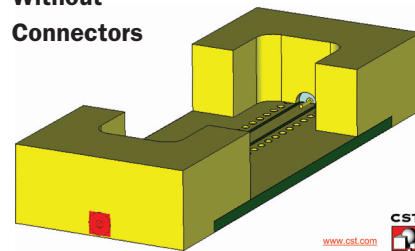

Simulation Results

The plot below is an overlay of the actual test data and the simulated data. The insertion loss has a dip at 45 GHz and the VSWR slowly rises over frequency from below 1.2:1 to 1.6:1 through 45 GHz. The magnitude of the loss is different but the shape is the same. The shape is the most important aspect as it is an indication of bandwidth. This plot shows good correlation of simulated to measured data.

The TDR shows the board impedance below 50 ohms and a capacitive dip on either end where the launch pin sits on the board. This also corresponds to measured data.

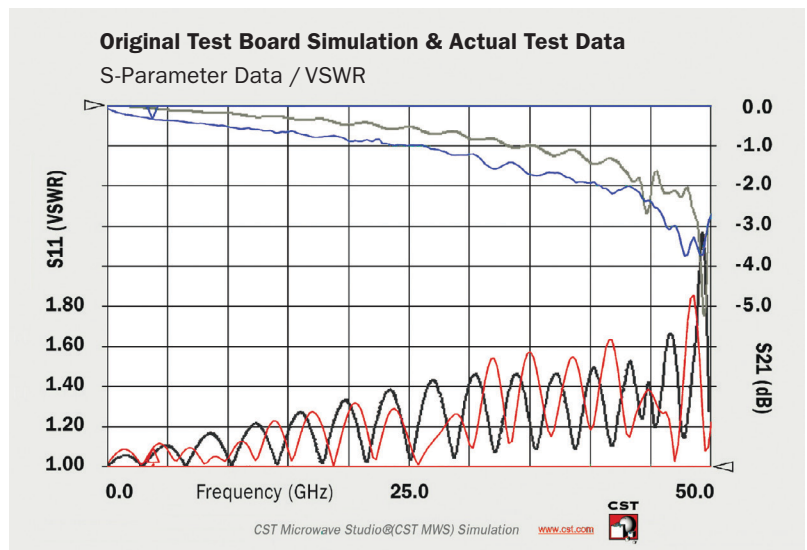
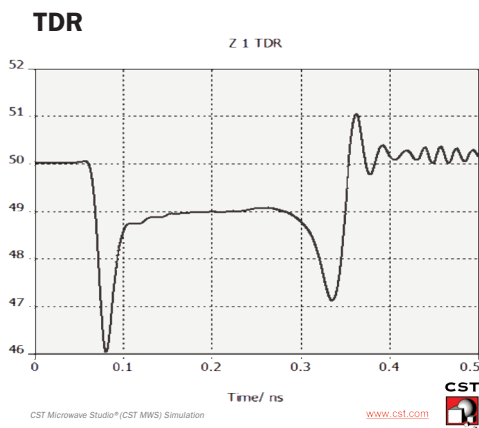

Simulation of original test board (shown in black & gray), **compared to actual measured data** (shown in red & blue).

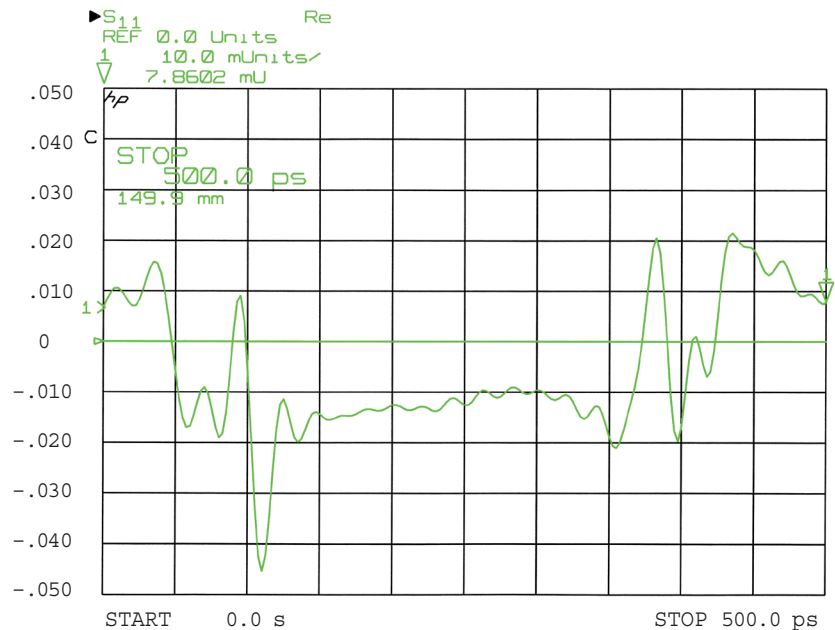
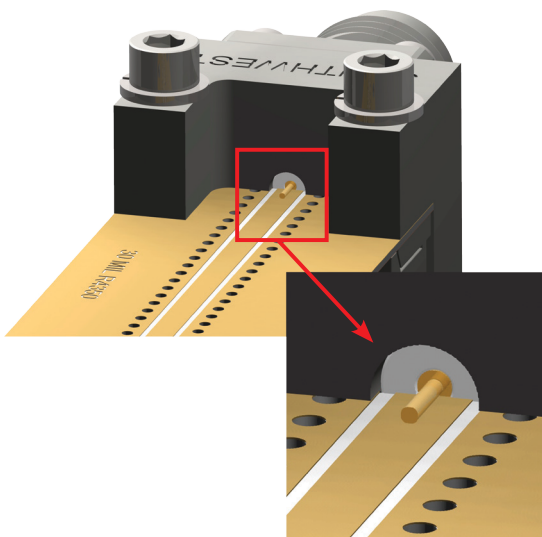

TDR of original coplanar test board (Serial Number Ø).

Taper (Version 1)

At the end of the board where the launch from the board's microwave transmission line structure to a coaxial line occurs there is a pin from the coax sitting on top of the board. This added metal creates an increase in capacitance that has to be addressed for optimal performance. The way to compensate for the capacitance of the pin is to add inductance to the board. This can be done in both microstrip and grounded coplanar waveguide (GCPWG) by narrowing the trace. The method used here is reducing the trace in what is referred to as a taper.

Taper (version 1)

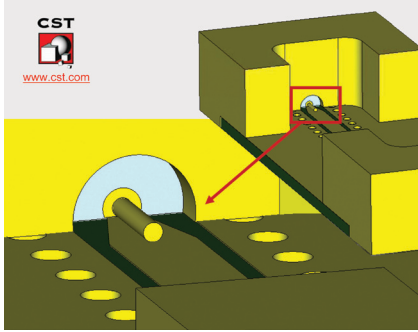

The traditional way a taper was determined at Southwest Microwave was to match the width of the trace with the coax launch pin, then taper it out to the proper microstrip width over the distance that the pin sits on the line. It has been shown in earlier test boards that this may be over-compensating for the capacitance, so the CST MWS 3-D model was again used to get a prediction.

Taper (version 1)

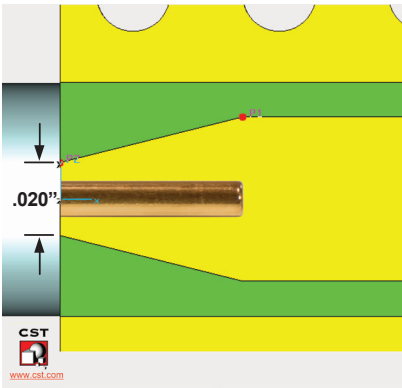

The S-Parameter results of the CST MWS model of the first taper design shows that it actually makes a worse match than no taper at all and causes ripple in the insertion loss. The TDR results of the simulation shows that even with the pin the circuit is too inductive right at the launch.

Comparison: Taper (version 1), and No Taper

TDR

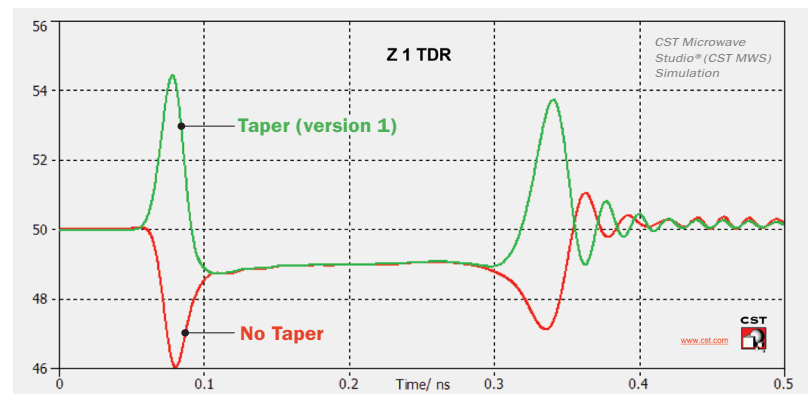

Taper (version 1)

Simulated S-Parameter Data / VSWR

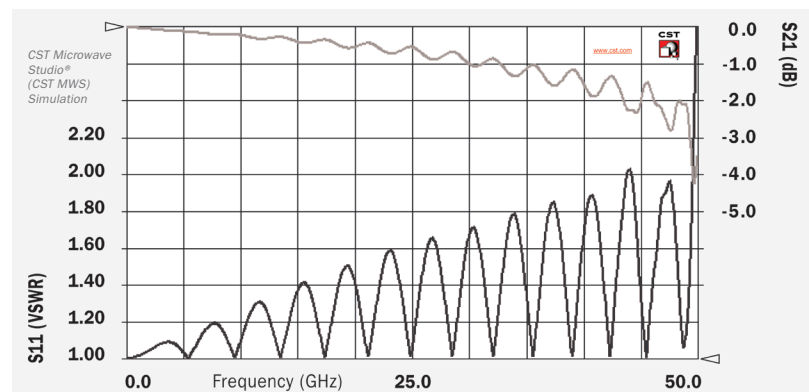

Enlarged view of coplanar test board

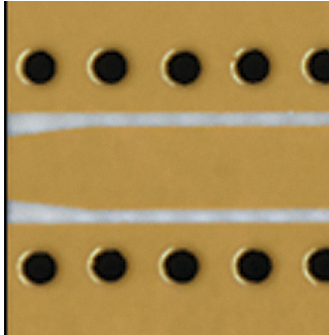

Optimized taper (version 2)

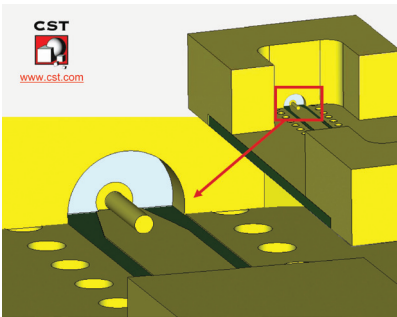

Optimized taper (version 2)

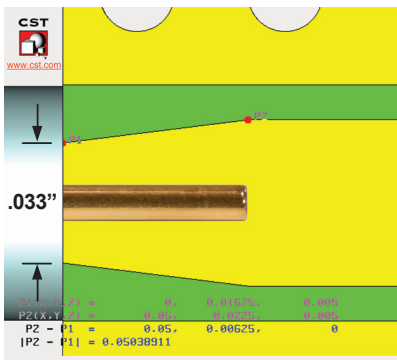

Optimized Taper (Version 2)

The second taper design was developed using the CST Microwave Studio® optimization routine. The taper length was kept the same, but the final width at the edge of the board was increased. This still adds some inductance to the board right at the launch, but it is less inductive than the first taper design. The simulation shows excellent results for S11, much better than could be realized in practice and the insertion loss is very smooth up to the normal 45 GHz glitch always seen. For a further discussion on this, see the paper “Optimizing Test Boards for 50 GHz End Launch Connectors” on www.southwestmicrowave.com. Boards were made and tested using this design and the plot below shows an overlay of the simulated and test data.

Comparison: Taper (version 1), Optimized Taper (version 2), No Taper TDR

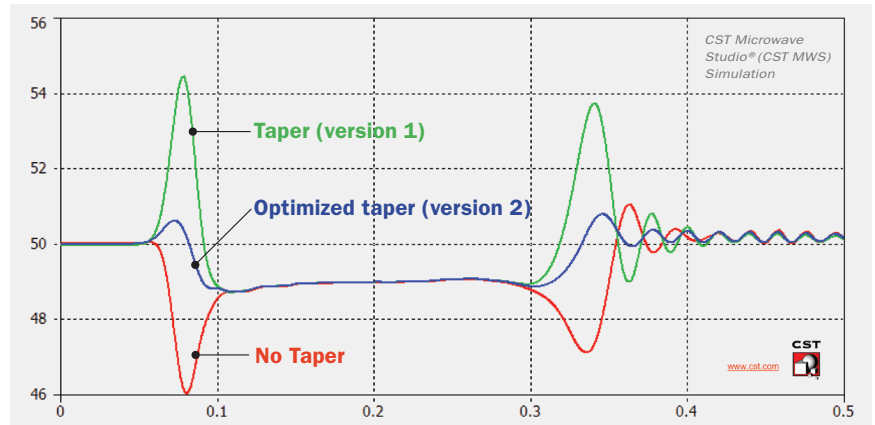

Optimized Taper (Comparison of Simulated vs. Measured Test Data)

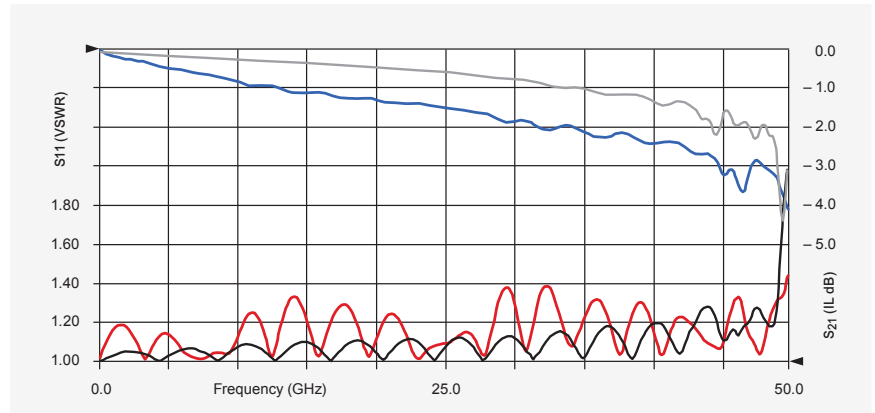

S₂₁ Simulated, S₂₁ Measured, VSWR Simulated and VSWR Measured Data

Optimized Designs – Final Layouts

Microstrip Layouts

The 8 mil microstrip board has a slight taper to account for the pin of the connector. The 30 mil board is more difficult to match and has quite a large taper to account for the pin of the connector. The 30 mil design was optimized through an empirical study, instead of with software, but is good enough to show the differences in the behavior of the lines.

Straight Microstrip

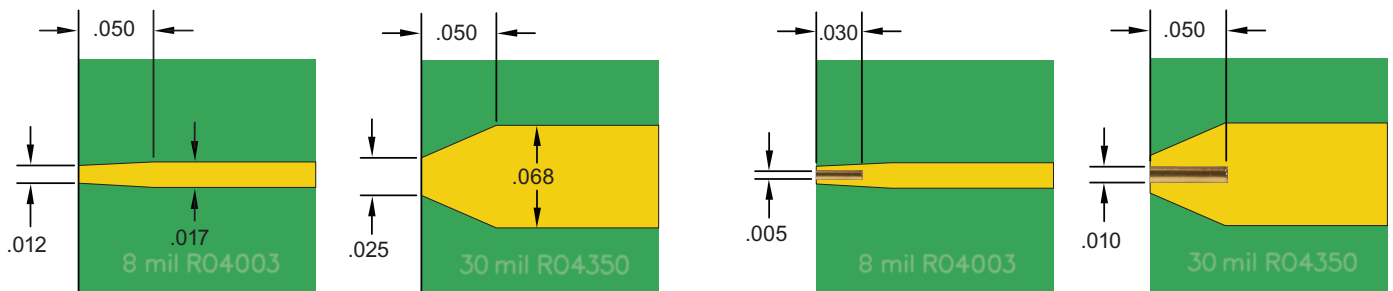

8 mil & 30 mil Straight Microstrip final board layout dimensions.

8 mil & 30 mil Straight Microstrip pin sizes relative to the board thickness.

Top Ground Microstrip

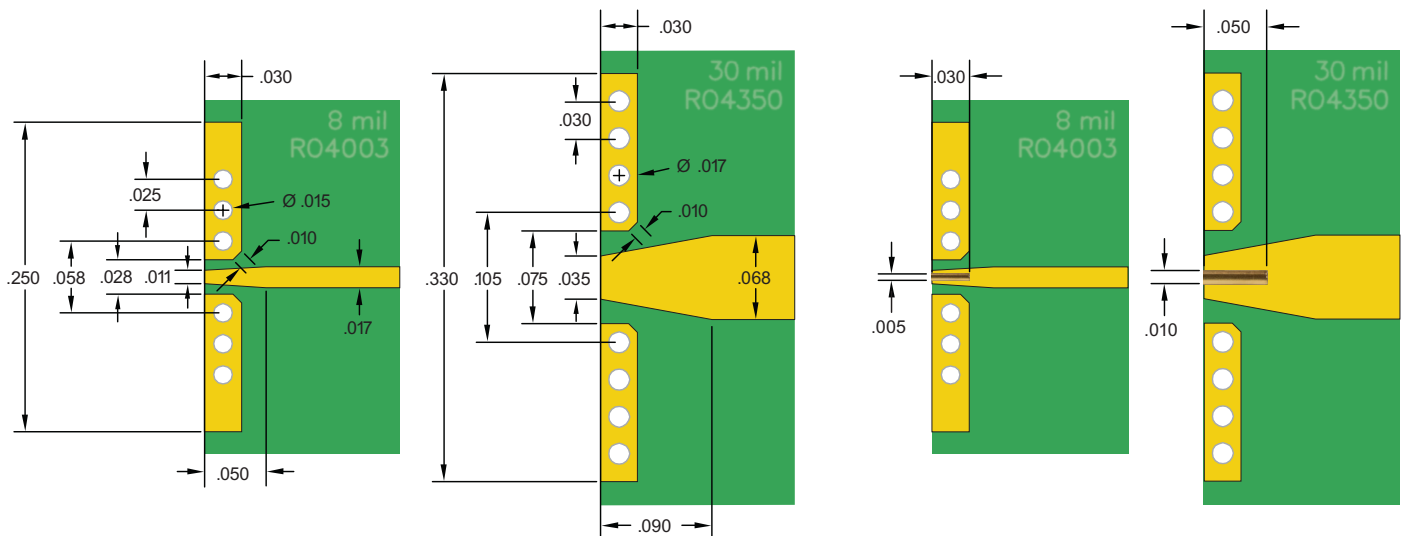

8 mil & 30 mil Top Ground Microstrip final board layout dimensions.

8 mil and 30 mil Top Ground Microstrip pin sizes relative to the board thickness.

GCPWG Layouts

The 8 mil GCPWG board again has a slight taper to account for the pin of the connector. The 30 mil board is slightly more difficult to match and has a moderate taper to account for the pin of the connector. This 30 mil design was optimized with software as seen in the example earlier in the paper.

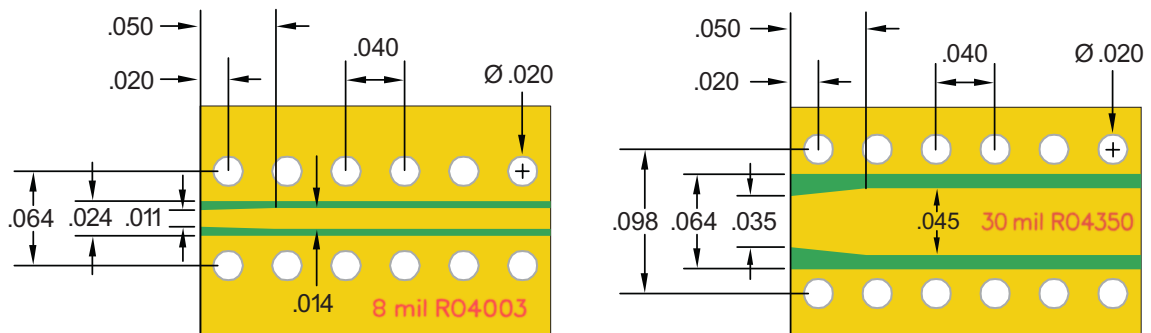

8 mil and 30 mil Straight Microstrip final board layout dimensions.

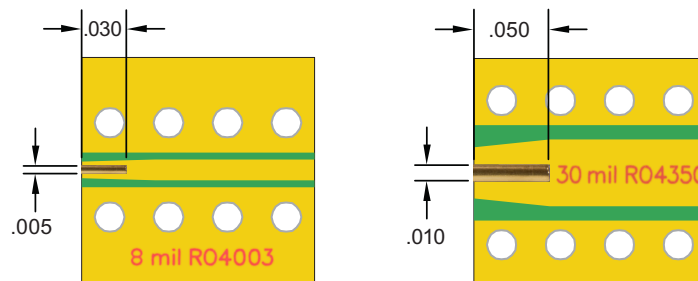

8 mil & 30 mil Straight Microstrip pin sizes relative to the board thickness.

Loss Data

Scope

This last section will be a comparison of the losses of the different line types. The comparisons were done on 1 inch long and 2.5 inch long test boards. This allowed loss per inch and loss per launch information to be extracted and is shown in the appendix. The same connectors were used. Some scaling of S21 is different to fit all of the data on graphs.

Loss (1" Straight Microstrip – Comparison of Board Thickness)

This data shows that a straight microstrip launch on 30 mil RO4350 has two distinct slopes depending on frequency. The low frequency loss is dominated by board loss and the high frequency loss is dominated by radiated loss. The 8 mil board has a better launch transition and does not radiate in the high frequency range.

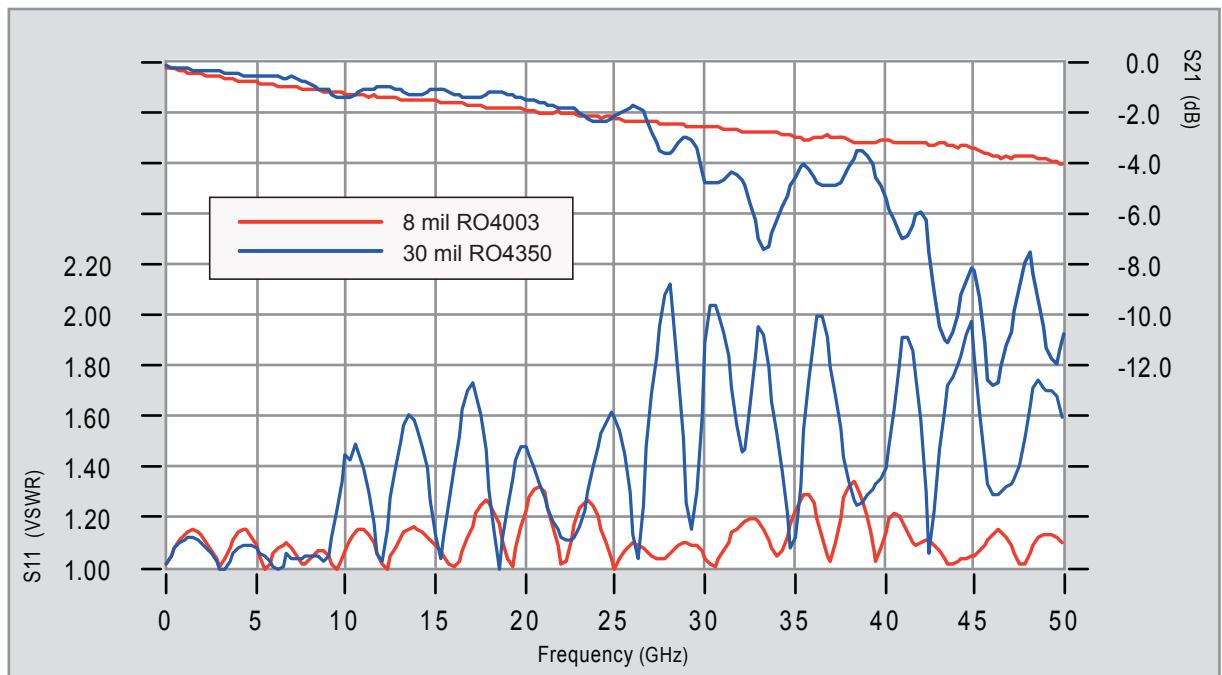
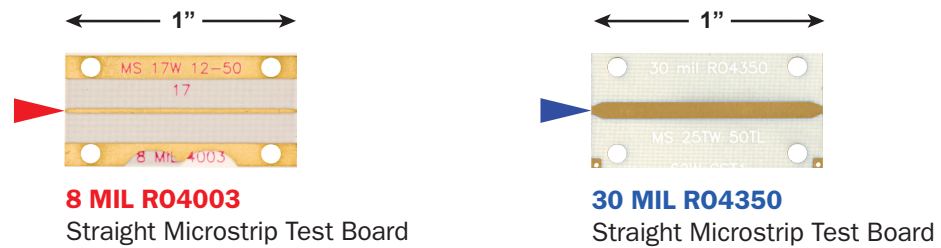

Actual Test Data for 1" Straight Microstrip Test Boards.

Loss (2.5" Straight Microstrip – Comparison of Board Thickness)

Again, this data shows how straight microstrip on 30 mil RO4350 has two distinct slopes depending on frequency. The low frequency loss is dominated by board loss and the high frequency loss is dominated by radiated loss. Note that even though the board is longer, the total loss is comparable at 50 GHz. This shows that the radiated loss is most likely occurring mostly at the launch. For a further discussion on this, see the paper “Optimizing Test Boards for 50 GHz End Launch Connectors” on www.southwestmicrowave.com.

At lower frequencies the 30 mil board has lower loss. This is because the line loss (loss per inch) is less. Longer boards would produce an even greater improvement in loss than an 8 mil microstrip board.

The 8 mil board loss stays linear and the loss significantly increased with the longer length. This indicates it is not radiating and that line loss is a significant portion of the total loss.

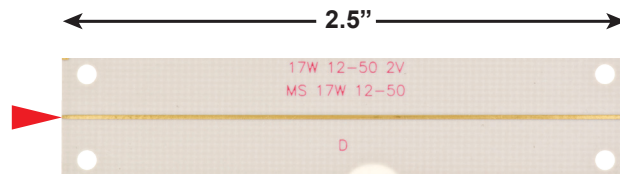

8 MIL RO4003
Straight Microstrip Test Board

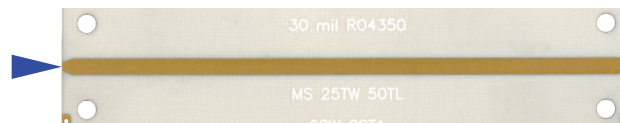

30 MIL RO4350
Straight Microstrip Test Board

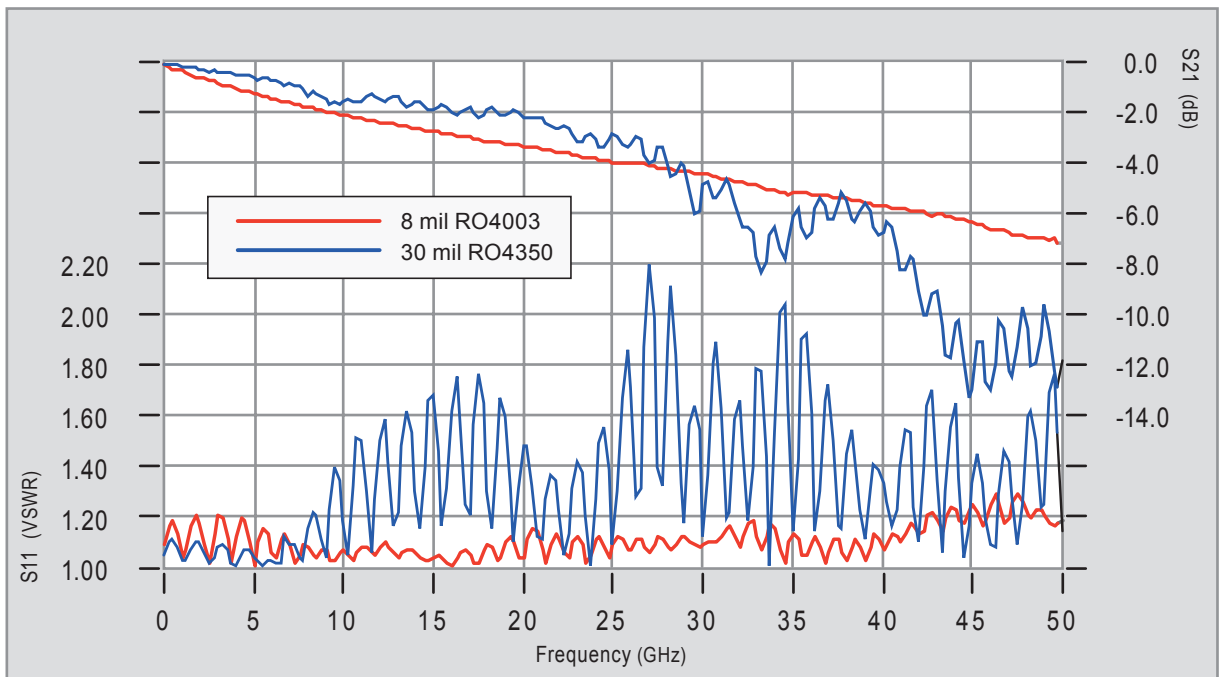

Actual Test Data for 2.5" Straight Microstrip Test Boards.

Loss (1" Top Ground Microstrip – Comparison of Board Thickness)

This data shows that a microstrip with a top ground launch on 30 mil RO4350 has two distinct slopes depending on frequency. The low frequency loss is dominated by board loss and the high frequency loss is dominated by radiated loss. To calculate board loss the low frequency region should be used.

At low frequencies the 30 mil board has less loss than the 8 mil board and at high frequencies the 8 mil board has less loss. This is due to the radiated loss of the 30 mil board at higher frequencies. For a further discussion on this, see the paper “Optimizing Test Boards for 50 GHz End Launch Connectors” on www.southwestmicrowave.com.

Adding the top ground to the launch reduces the total loss on the 30 mil board from 12 dB to 6 dB.

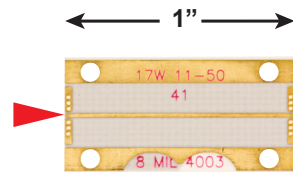

8 MIL R04003
Top Ground Microstrip Test Board



30 MIL R04350
Top Ground Microstrip Test Board

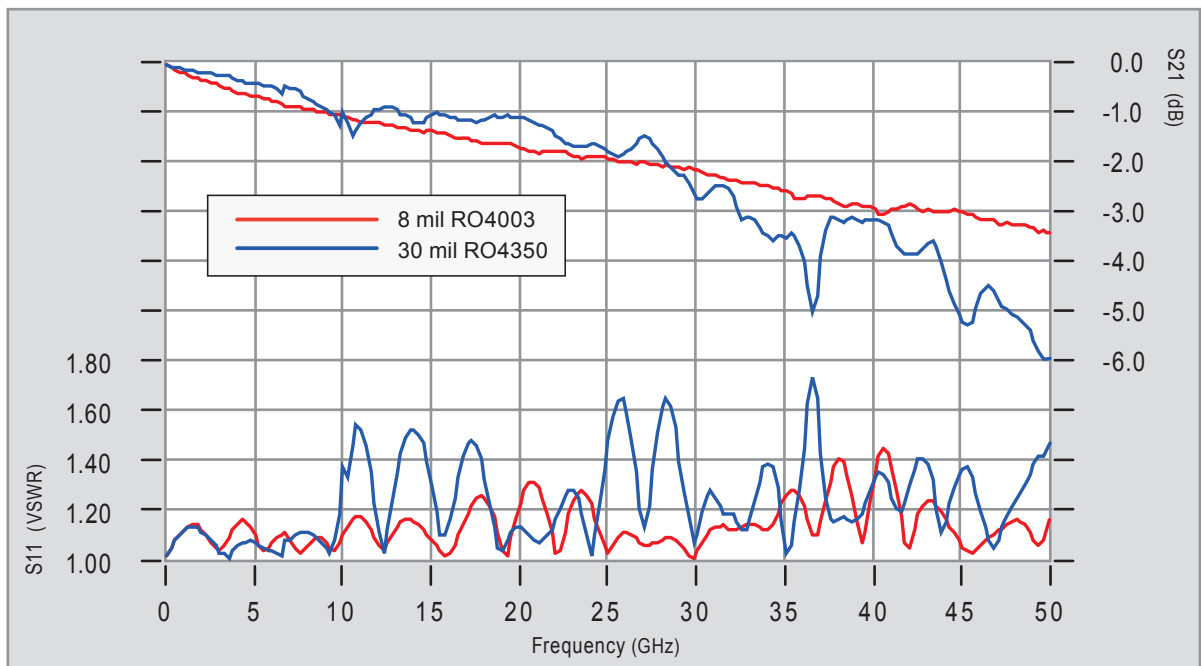

Actual Test Data for 1" Top Ground Microstrip Test Boards.

Loss (2.5" Top Ground Microstrip – Comparison of Board Thickness)

Again this data shows how microstrip with a top ground launch on 30 mil RO4350 has two distinct slopes depending on frequency. The low frequency loss is dominated by board loss and the high frequency loss is dominated by radiated loss. Note that even though the board is longer, the total loss is comparable to the 1" board. This shows that the radiated loss is most likely occurring mostly at the launch.

The 30 mil has significantly less loss than the 8 mil until 50 GHz. The difference at 25 GHz is over a dB.

Adding the top ground on the 30 mil board reduced the total loss from 12 dB to 8 dB.

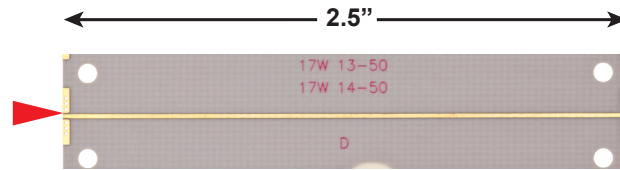

8 MIL RO4003
Top Ground Microstrip Test Board



30 MIL RO4350
Top Ground Microstrip Test Board

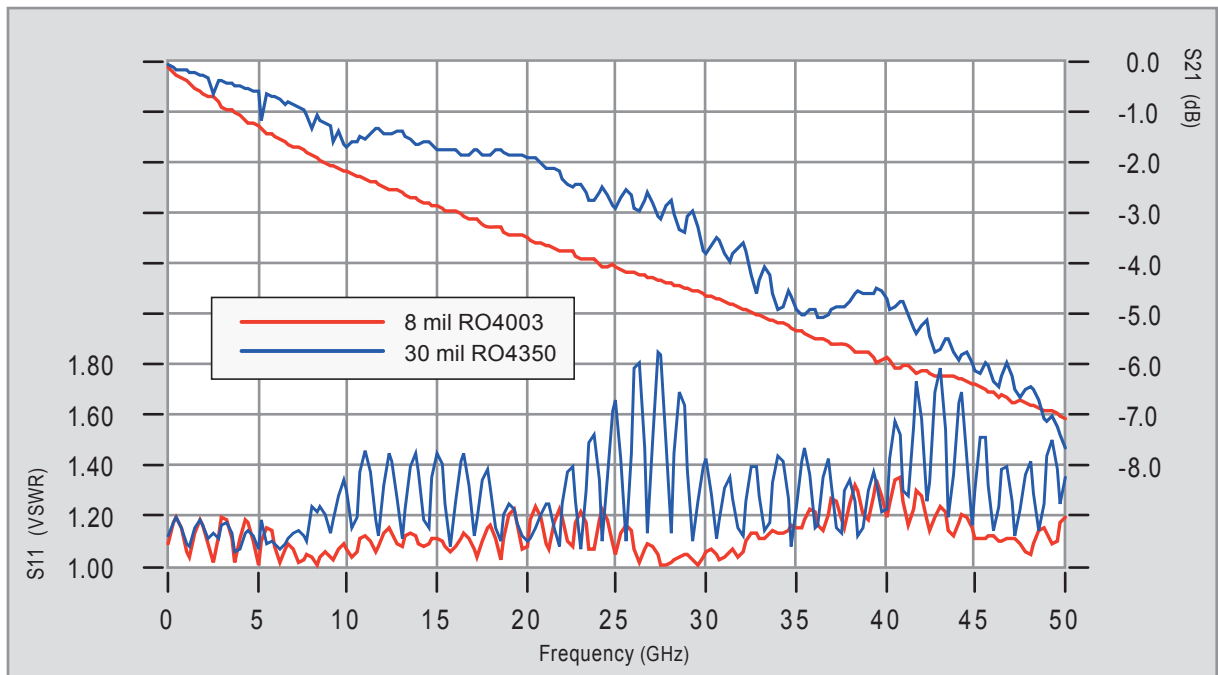

Actual Test Data for 2.5" Top Ground Microstrip Test Boards.

Advantages of Top Ground Microstrip on 30 mil Boards

1" (30 mil) Top Ground vs. Straight Microstrip Test Boards

This is a comparison of two 1" long boards that are both made out of 30 mil R04350. This data demonstrates the advantages of adding a top ground to a microstrip launch on thicker boards. At the low frequencies the loss is essentially the same. At high frequencies the straight microstrip starts to radiate more at the launch. The total loss of the top ground board is 8 dB and the total loss of the straight microstrip it is 12 dB.

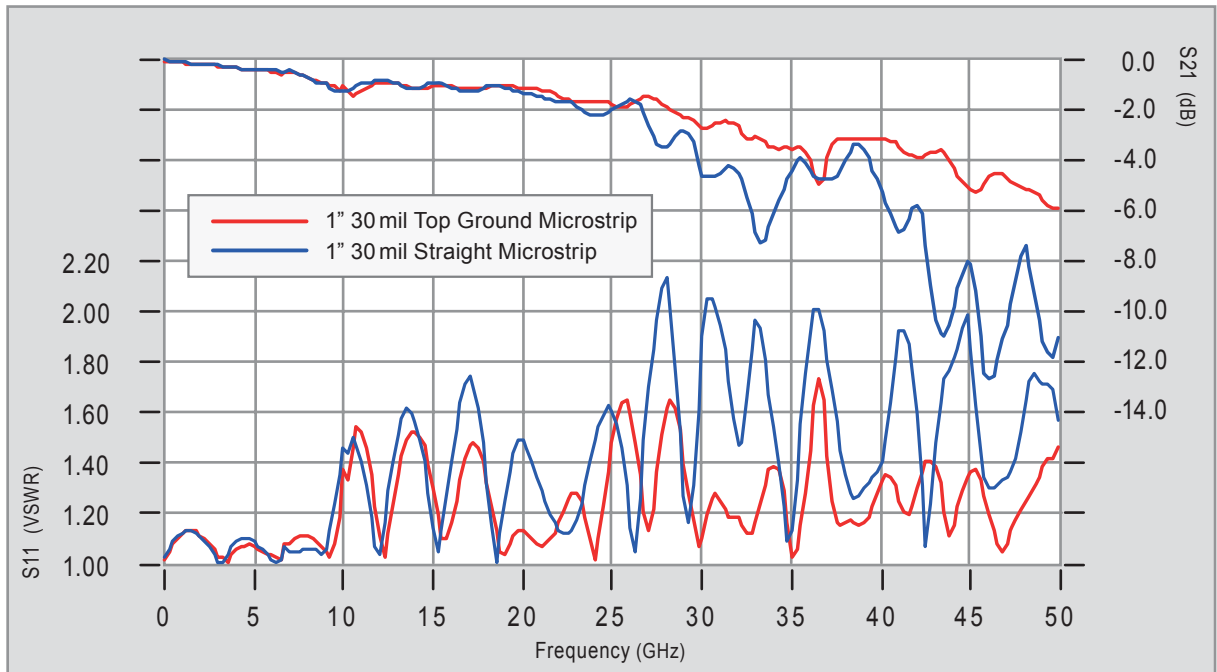
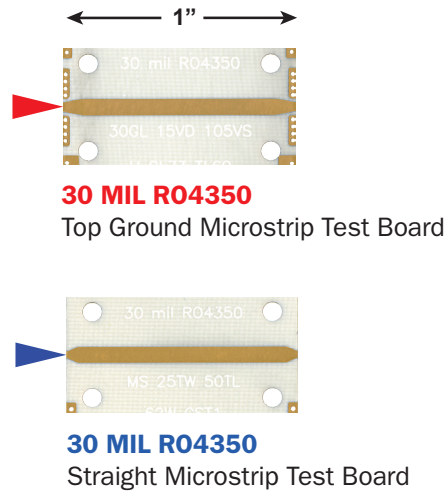

Actual Test Data for 1" 30 mil Top Ground and Straight Microstrip Test Boards.

Advantages of Top Ground Microstrip on 30 mil Boards

2.5" (30 mil) Top Ground vs. Straight Microstrip Test Boards

This is a comparison of two 2.5" long boards that are both made out of 30 mil R04350. This data demonstrates the advantages of adding a top ground to a microstrip launch on thicker boards. At the low frequencies the loss is essentially the same. At high frequencies the straight microstrip starts to radiate at the launch. The total loss of the top ground board is 8 dB and the total loss of the straight microstrip it is 12 dB.

← 2.5" →

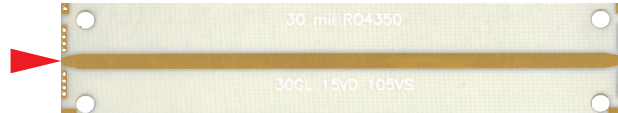

30 MIL R04350

Top Ground Microstrip Test Board

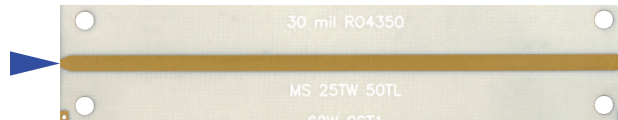

30 MIL R04350

Straight Microstrip Test Board

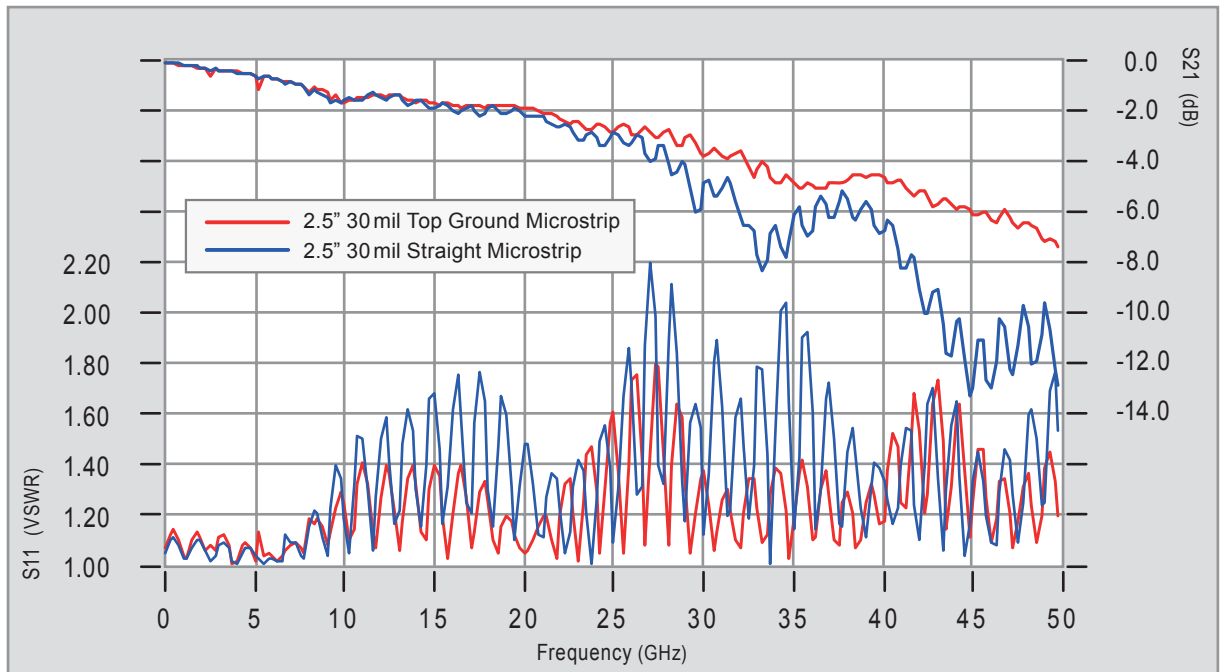

Actual Test Data for 2.5" 30 mil Top Ground and Straight Microstrip Test Boards.

Loss (1" GCPWG – Comparison of Board Thickness)

This data shows how grounded coplanar waveguide (GCPWG) on 30 mil R04350 has a linear loss curve over frequency. There is not the radiated loss that the microstrip boards have, but the board loss is significantly higher. The loss is dominated by line loss (loss per inch) and there is very little energy being radiated.

The 8 mil board has more loss than the 30 mil board. The difference is about 1 dB at the higher frequencies.

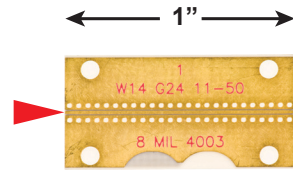

8 MIL R04003
GCPWG Test Board

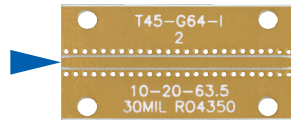

30 MIL R04350
GCPWG Test Board

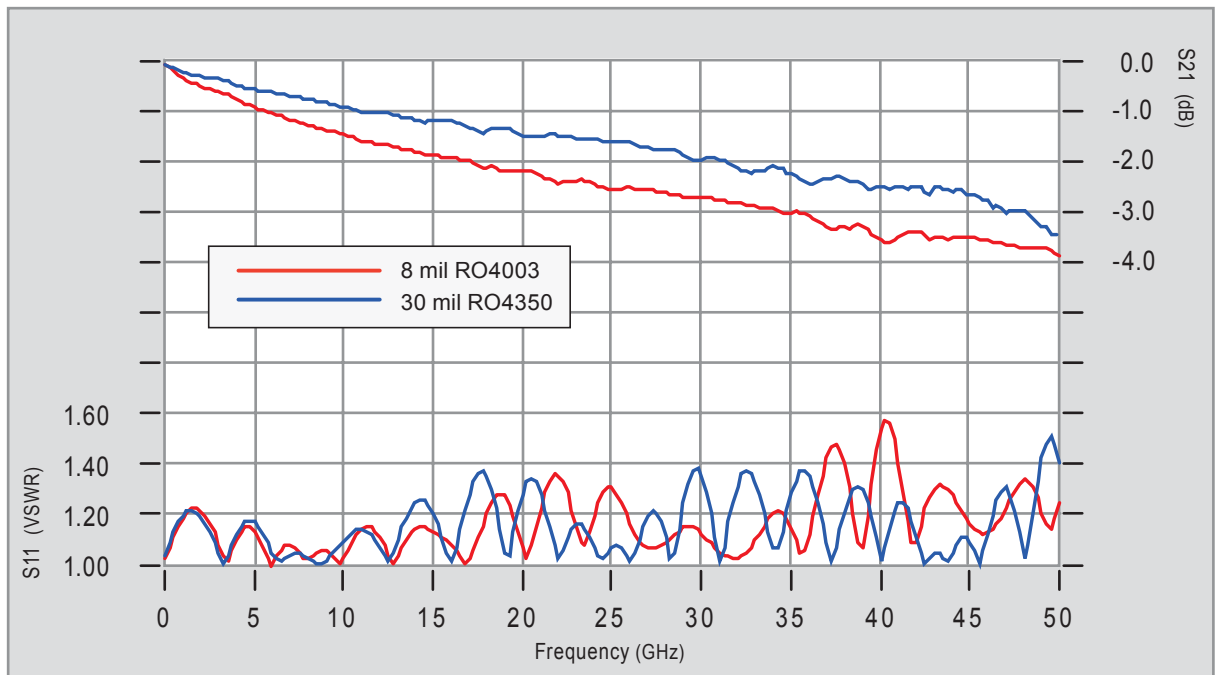

Actual Test Data for 1" GCPWG Test Boards.

Loss (2.5" GCPWG – Comparison of Board Thickness)

Again this data shows how GCPWG on 30 mil RO4350 has a linear loss curve over frequency. But the higher board loss can make longer GCPWG boards have significantly higher loss at frequencies where microstrip board loss is not swamped by radiated losses.

There is an even bigger difference in loss between the 2 boards than the 1 inch boards - about 2 dB at the higher frequencies. This is because the loss is line loss (loss per inch) so the longer the board the greater the difference will be.

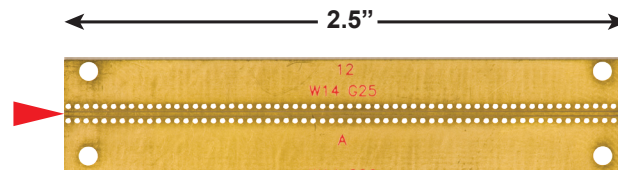

8 MIL RO4003
GCPWG Test Board



30 MIL RO4350
GCPWG Test Board

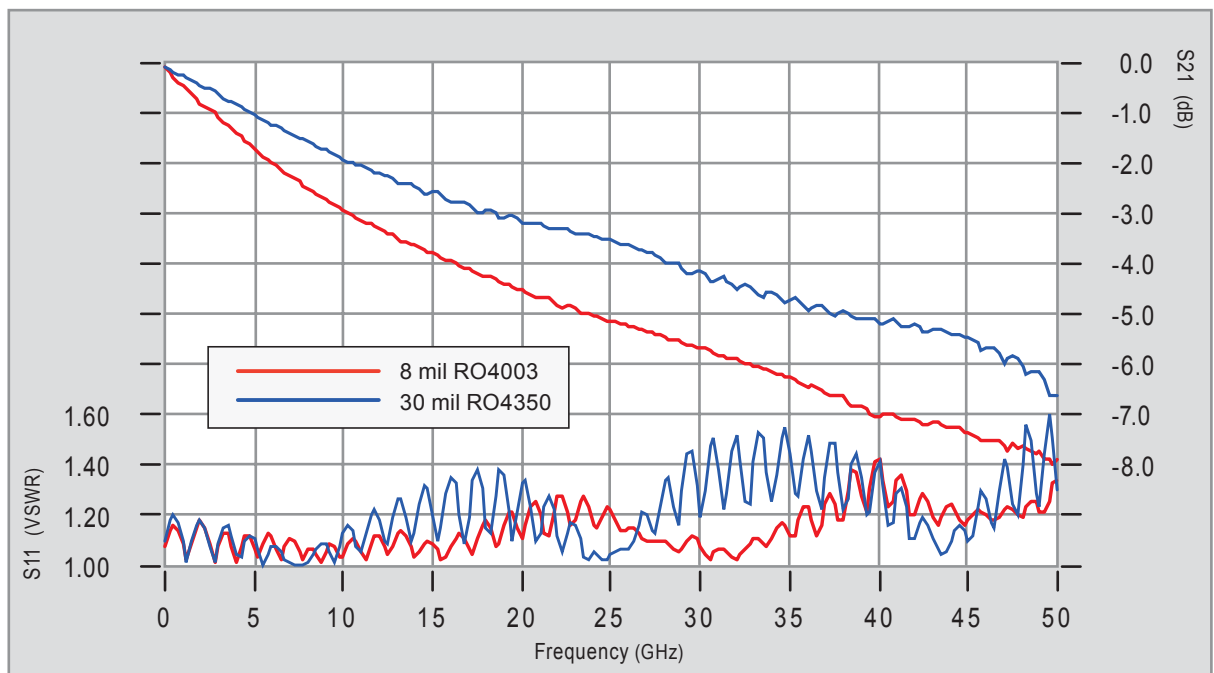

Actual Test Data for 2.5" GCPWG Test Boards.

Conclusion

In choosing a board thickness the trade-offs between thick (in this case 30 mil R04350) and thin (in this case 8 mil R04003) substrates need to be considered. This paper demonstrated these trade-offs with test data from many examples of both thicknesses. It is also shown that with Rogers 4000 series material it is advantageous to match the connector to the substrate based on thickness. This paper examined the reasoning for this and went through the process of creating and testing the substrates.

First the end launch connectors used for this evaluation, including their operation and advantages, were described in detail. It was shown graphically that for different thicknesses of substrates it is best to match the board thickness to a suitably sized connector. Then Southwest Microwave test methods were described along with how test data is presented. The types of transmission lines and launches evaluated in this paper were reviewed and terminology was defined.

An example of a board launch optimization was described in detail for GCPWG on 30 mil R04350. It showed how to combine TDR test methods and 3-D electromagnetic simulation to design a well matched launch. It was shown that only a small part of the connector was needed in the simulation to get accurate results. Boards were made using the optimized design and proved that the optimization worked.

The six optimized launch designs were shown in detail in views with and without the connector pins to show the relative launch sizes. Boards were made of all of the launch designs in two different lengths to show the comparative performances. Finally, all of the test data was shown and compared.

Microstrip lines on 8 mil RO4003 have a better match and have bandwidth greater than 50 GHz. Microstrip lines on 8 mil RO4003 have more loss at lower frequencies than microstrip lines on 30 mil RO4350. Microstrip lines on 30 mil RO4350 have a poor match and even with a top ground launch do not reach 50 GHz of bandwidth.

GCPWG lines have 50 GHz of bandwidth on both 8 mil RO4003 and 30 mil RO4350 with the 8 mil RO4003 having more loss. Both substrates have more loss as compared to microstrip lines.

Both of these substrates can be made to work up to 50 GHz so the choice of board thickness depends on which substrate is best suited to meet the needed requirements.

Straight Microstrip Loss (Summary)

	8 mil RO4003		30 mil RO4350	
	Loss/Inch	Loss/Launch	Loss/Inch	Loss/Launch
5 GHz	0.4	0.1	0.1	0.1
10 GHz	0.7	0.2	0.2	0.2
15 GHz	0.9	0.2	0.3	0.3
20 GHz	1.1	0.2	0.4	0.4
25 GHz	1.4	0.2	0.5	0.5
30 GHz	1.5	0.3	0.7	1.3
35 GHz	1.8	0.4	0.9	2.3
40 GHz	1.9	0.5	1.1	3.3
45 GHz	2.1	0.5	1.3	4.3
50 GHz	2.3	0.7	1.5	5.3

Test Data comparison for Straight Microstrip 8 mil RO4003 and 30 mil RO4350 calculated from 1" and 2.5" board data.

Top Ground Microstrip Loss (Summary)

	8 mil RO4003		30 mil RO4350	
	Loss/Inch	Loss/Launch	Loss/Inch	Loss/Launch
5 GHz	0.4	0.1	0.1	0.1
10 GHz	0.7	0.2	0.2	0.2
15 GHz	1.0	0.2	0.3	0.3
20 GHz	1.2	0.2	0.4	0.4
25 GHz	1.4	0.2	0.5	0.5
30 GHz	1.6	0.2	0.6	0.6
35 GHz	1.8	0.3	0.8	0.9
40 GHz	2.0	0.3	1.0	1.3
45 GHz	2.3	0.3	1.1	1.7
50 GHz	2.5	0.3	1.3	2.0

Test Data comparison for Top Ground Microstrip 8 mil RO4003 and 30 mil RO4350 calculated from 1" and 2.5" board data.

GCPWG Loss (Summary)

	8 mil RO4003		30 mil RO4350	
	Loss/Inch	Loss/Launch	Loss/Inch	Loss/Launch
5 GHz	0.5	0.17	0.2	0.03
10 GHz	1.0	0.19	0.5	0.07
15 GHz	1.3	0.25	0.7	0.10
20 GHz	1.5	0.29	0.9	0.13
25 GHz	1.7	0.35	1.2	0.17
30 GHz	1.9	0.36	1.4	0.20
35 GHz	2.1	0.38	1.6	0.23
40 GHz	2.3	0.40	1.9	0.27
45 GHz	2.5	0.41	2.1	0.30
50 GHz	2.7	0.48	2.3	0.33

Test Data comparison for GCPWG 8 mil RO4003 and 30 mil RO4350 calculated from 1" and 2.5" board data.



The Performance Leader in Microwave Connectors

Southwest Microwave, Inc. is the leader in hi-performance interconnect products for millimeter wave and microwave applications. Providing the best value through performance as well as:

- *Low VSWR*
- *Low Insertion Loss*
- *Low RF Leakage*
- *High Temperature*
- *Higher Power Handling*
- *Excellent Repeatability*
- *Rugged & Durable*

Visit us on-line @: www.southwestmicrowave.com

Southwest Microwave, Inc.

9055 S. McKemy St., Tempe, AZ 85284-2946 USA

Phone: 480.783.0201 ■ Fax: 480.783.0360